

ELEVATION

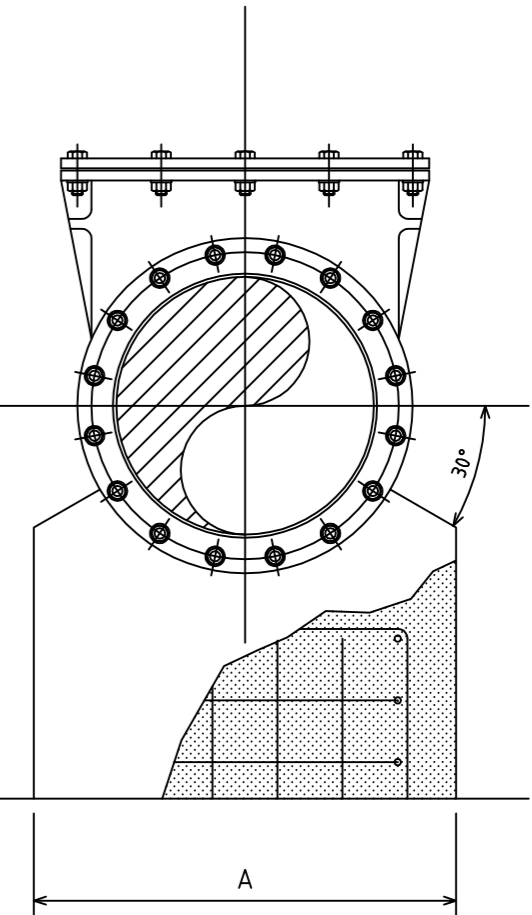

END ELEVATION

VALVE NOMINAL DIAMETER	DN 100	DN 150	DN 200	DN250	DN 300	DN 375	DN 450	DN 500	DN 600	DN 700	DN 750	DN 800	DN 900
A	300	370	430	480	550	620	750	820	900	1100	1200	1300	1400

NOTES:

1. CLEARANCE DIMENSION TO BE FLANGE BOLT LENGTH 40mm
2. CONCRETE TO BE N25 TO AS3600
 - i) SLUMP 80mm MAX
 - ii) AGGREGATE SIZE 20mm MAX
3. MINIMUM COVER TO REINFORCEMENT TO BE 65mm

1	CONSTRUCTION	S.H.	1-06-2016
REV. N°	REVISION	APPROVED	DATE
© COPYRIGHT HUNTER WATER CORPORATION LIMITED.		APPROVED MANAGER ASSET MANAGEMENT	



STANDARD CONSTRUCTION PRACTICE
SEWERAGE STANDARD
 SEWAGE PUMPING STATIONS
 CONCRETE SUPPORTS
 FOR STOP VALVES AND REFLUX VALVES

CAD FILE NAME: SCP-908

HWCS
SCP-908

ISSUED: 2016

A3