



HUNTER WATER CORPORATION

**WATER AND SEWER
DESIGN MANUAL**

**SECTION 7
TANK / RESERVOIR STANDARDS**

Document Control

Document Owner	Manager Asset Management
Date of Next Review	1 May 2013
File Name	Design Manual Section 7 – Reservoir / Tank Design
File Reference	HW2009-2368/1/7

Revision History

Revision	Changes	Issue Date	Approved By
1.1	Final Draft	October 2010	S Horvath
1.2	<p>Final</p> <p>All – Renumbered to be consistent with Design Manual, prefix numbering 7 added</p> <p>Clause amended -7.10.3– Additional commentary on outlet pipe positioning.</p> <p>Clause amended - 7.10.5 – Additional commentary on concrete reservoir scour point.</p> <p>Clause amended - 7.18.2.2 – Precast post tension concrete design / construction considerations</p> <p>Clause added - 7.18.2.8 – Joint sealing requirements</p> <p>Clause amended - 7.19.3– Hinged cover and winch for vehicle access cover</p> <p>Clause amended - 7.19.4 – Winch for heavy duty cover</p> <p>Clause amended - 7.19.5 – Ladder height for fall arrest specified</p> <p>Clause Amended - 7.28 (previously clause 27) – Documentation requirements</p>	April 2011	S Horvath

TABLE OF CONTENTS

7.1	Introduction	4
7.1.1	General	4
7.1.2	Design Objectives	4
7.2	Construction Methodology	5
7.3	Location	5
7.4	Land Selection	6
7.5	Location Factors	6
7.6	Easements	8
7.7	Site Survey	8
7.8	Geotechnical	8
7.9	Road Access	8
7.10	Hydraulic Design	9
7.10.1	Inlet Pipework	9
7.10.2	Automatic Inlet Valves (Aiv).....	9
7.10.3	Outlet Pipework.....	9
7.10.4	Overflow.....	9
7.10.5	Scour / Washout Bulkhead	10
7.10.6	Washdown Hydrant	10
7.10.7	Site Discharge Structure	10
7.11	Water Quality Aspects	10
7.11.1	Mixing Of Storage	10
7.11.2	Ventilation / Vermin Proofing Details	11
7.11.3	Inlet Nozzles	11
7.11.4	Re-Chlorination	11
7.11.5	Stormwater Management Details	11
7.12	Boundary Fencing	12
7.13	Landscaping	12
7.14	Design Life	12
7.15	Whole Of Life Costs	13
7.16	Durability	13
7.16.1	Thermal Effects.....	14
7.16.2	Dissimilar Metals.....	14
7.17	Preferred Equipment List	14
7.18	Structural Design	15
7.18.1	Fabricated Mild Steel.....	15
7.18.2	Reinforced Concrete Tanks (Cast In-Situ & Pre-Cast).....	15
7.18.2.1	Cast In-Situ.....	16
7.18.2.2	Pre-Cast Post Tensioned	16
7.18.2.3	Concrete Mix Design Requirements.....	16
7.18.2.4	Aggregates	17
7.18.2.5	Addition Of Water.....	17
7.18.2.6	Chemical Admixtures.....	17
7.18.2.7	Cover Requirements.....	17
7.18.2.8	Joint Sealing.....	18
7.18.2.9	Concrete Repairs.....	18
7.18.2.10	Watertightness Test.....	18
7.18.3	Bolted Steel Tanks.....	18
7.19	Roof Access	18

7.19.1	Roof Access Stairs	18
7.19.2	Roof Platform	19
7.19.3	Maintenance Access Vehicle Hatch	19
7.19.4	Roof Access Hatch	19
7.19.5	Internal Ladder	19
7.19.6	Eyebolts	20
7.19.7	Davit And Lifting Gear	20
7.20	Wall Strake Access (Fabricated Steel Only)	20
7.20.1	Personnel Access Hatches	20
7.20.2	Ventilation Hatch	20
7.21	Steel Floor Plates	21
7.22	Columns	21
7.23	Sampling Arrangement	21
7.24	Reservoir Testing	21
7.24.1	General	21
7.24.2	Mild Steel Fabricated Tanks	21
7.24.2.1	Floor Testing	21
7.24.2.2	Wall Testing	22
7.24.3	Foundations	22
7.24.4	Hydrostatic Testing	22
7.24.5	Overflow / Scour	22
7.25	Coating Systems For Fabricated Steel Tanks	22
7.25.1	General	22
7.25.2	Surface Preparation	23
7.25.2.1	Procedure	23
7.25.2.2	Abrasive Material	23
7.25.3	Coating Materials	23
7.25.3.1	Reservoir Internal Surfaces	23
7.25.3.2	External Surfaces (Coastal Tank <5km To The Coast)	24
7.25.3.3	External Surfaces (Inland Tank >5km To Coast)	24
7.26	Cathodic Protection (Cp) System	24
7.26.1	General	24
7.26.2	Location Of Facilities	24
7.26.3	Anodes	24
7.26.4	Electrodes	25
7.26.5	Test Point	26
7.26.6	Cabling	26
7.27	Electrical	26
7.27.1	Power Supply	26
7.27.2	Switchboard	26
7.27.2.1	Metering of Incoming Power Supply	27
7.27.2.2	PLC Telemetry and Instrumentation Cubicle	27
7.27.2.3	Radio Path Survey	27
7.27.3	Level Instruments	28
7.27.4	Security	28
7.27.5	Lighting	28
7.27.6	Site 230v Gpos	28
7.27.7	Lightning Protection	28
7.28	Design Documentation And Drawings	29
7.28.1	Design Design	29
7.28.2	Electrical Design	29
7.28.3	Operating And Maintenance	29

TABLES

Table 1 Planning and Design Factors for Reservoirs	5
Table 2 Location Factors	7
Table 3 Asset Design Life.....	12
Table 4 Coastal Tank Material Requirements (<5km from coast).....	13
Table 5 Inland Tank Material Requirements (>5km from coast)	14
Table 6 Concrete Mix Requirements	16
Table 7 Minimum Concrete Cover.....	17

APPENDICES

Appendix A	-	Tank / Reservoir Standard Drawings
------------	---	------------------------------------

7.1 INTRODUCTION

7.1.1 GENERAL

The objective of this document is to standardise and reduce the variability in tank / reservoir designs undertaken for and behalf of the Corporation.

This document sets out to provide guidance by way of general principles, criteria and good practice. This document shall be looked upon as being applicable in the majority of situations and should be read in conjunction with Hunter Water Standard Technical Specifications and Drawings.

Also provided are typical layout and arrangement drawings, which detail the minimum design, operational and maintenance requirements.

Where the word 'reservoir' is used in this document, it should also be read as applicable to 'tank' for use on other storages such as reclaimed water tanks and clear water tanks etc.

The Corporations reservoirs are normally taken offline as part of a programmed cleaning and maintenance schedule, therefore reducing the requirement for diver access on a regular basis.

This document does not relieve the designer's responsibility for compliance with relevant Australian and International standards and use sound engineering judgement for all aspects of the design. The designer must justify in a designers report any variation from the minimum requirements set out in this document.

7.1.2 DESIGN OBJECTIVES

In principle, the reservoir design objectives are to achieve the following criteria:

- the reservoir is to be functional
- ensure ease of maintenance
- ensure reliable operation
- ensure fitness for purpose
- ensure water quality is not degraded
- ensure ease of constructability
- minimise adverse environmental and community impact
- comply with environmental requirements
- comply with OH&S requirements
- minimise energy consumption by efficient operation
- achieve extended service life with minimal maintenance and least whole of life cost.
- provide adequate weather protection and stormwater management
- provide adequate ventilation to minimise corrosion
- provide sufficient vehicular and personnel access for maintenance

Installations are to be planned and designed with particular reference to the following practice:

Table 1 Planning and Design Factors for Reservoirs

Factors	Requirements
Functionality	Efficiently receive store and deliver
	Maintain water quality
	Operation to comply with the requirements outlined in the HWC Water and Sewer Design Manual
	Meet regulatory requirements
	Have minimum visual impact on neighbourhood
	Incorporate remote monitoring, control and telemetry alarms
	Provide safe working conditions for operation and maintenance personnel
Maintainability	Be designed for minimal operator attendance and low maintenance
	Be easily maintained using standard maintenance practices
	Incorporate features to allow for flexibility of operation
	Utilise standard components that are readily available and interchangeable
Reliability	Operate reliably, effectively and automatically (i.e. normally unattended)
	Have redundancy so that failure of any one item shall not cause total failure
	Incorporate adequate security measures

7.2 CONSTRUCTION METHODOLOGY

The following reservoir construction methods are acceptable:

- Fabricated Mild Steel
- Cast In-situ Reinforced Concrete
- Pre-cast Post Tensioned Concrete

Where the reservoir is founded on sound rock all of the above options are acceptable.

For sites where the reservoir is to be founded on residual soils, or is subject to potential differential settlement or is located within a mine subsidence area, provide fabricated mild steel only. Consideration may be given to acceptability of concrete reservoirs where appropriate foundation treatment such as piling is adopted.

To reduce the OHS risks of confined space entry via the roof platform, there is a preference for fabricated mild steel tanks with side wall hatch access to the reservoir for cleaning and maintenance activities.

7.3 LOCATION

The location of a reservoir is strongly influenced by hydraulic considerations so that the network can operate satisfactorily under the design demand conditions.

The location shall be selected so that water pressure to consumers meets Hunter Water's criteria.

Given normal latitude, the choice of site is usually determined by land availability and aesthetic conditions, but the location should allow for a suitable layout for the inlet / outlet, scour, overflow pipework and discharge structure.

To ensure that the proposed reservoir location and layout are acceptable, the proposed site shall be approved in advance by Hunter Water.

7.4 LAND SELECTION

The order of preference for land choice for a reservoir site shall be:

- Land provided within the development by the person or business that is developing the land or their agent. (Hunter Water is to be given title or easement rights)
- Hunter Water owned land (if Hunter Water is the developer)
- Council land (Community land/Operational land)
- Vacant Crown land.
- Established private property
- Vacant private property
- Established Crown land
- Road reserve

Obtain easement rights or freehold title (vested in Hunter Water) for any reservoir sites, access and services. The reservoir shall be contained within an easement if wholly within a public reserve or a designated lot if not within a public reserve. The easement or lot is to include batters, embankments and retaining walls. Access and services should be contained within an easement.

Consideration should also be given to the potential likelihood of future development to enable a future storage of similar size within the site footprint.

7.5 LOCATION FACTORS

The following factors shall be considered during the site selection process:

Table 2 Location Factors

Factors	Requirements
Site selection	Located on a lot, ownership of which is dedicated to Hunter Water or an easement dedicated to Hunter Water
	Provide all weather access to the reservoir for routine and emergency operation and maintenance activities
	Sufficient space for flowmeter
	Power facilities should be available or able to be economically provided to the site
	Adequate radio communication access (radio path survey required)
	Site should have available safe access and consideration should also be given to construction and maintenance requirements. A deceleration lane may be applicable in some cases
Amenity and environment	Provision of sufficient buffer from houses, built-up areas and future development
	The reservoir should be unobtrusive, comply with DEC noise control requirements and preferably be screened by trees and shrubs
	Develop a landscape plan at the design stage in consultation with local residents and Council
Design	Proximity to pipelines
	Accessibility
	Site slope and soil conditions
Easements	Easements for the site and services may be necessary
Flooding	Ensure that adequate stormwater management drainage from the site including access roads is designed so that flooding of the facility is avoided
	The site and access road shall not be liable to flooding during a 1 in 100 year ARI
Supporting Systems	<p>In conjunction with determining the requirements for the site infrastructure, the designer shall consider the requirements for supporting systems to enable efficient and safe operation of the reservoir, as follows:</p> <ul style="list-style-type: none"> water supply (hydrant) power and general lighting security telemetry (radio path survey required)

7.6 EASEMENTS

As part of the planning phase, obtain all property easements for the access road, pipework, services, stormwater drainage and power supply. Site layout shall be arranged to minimise the number of easements. If possible, underground power supply shall not cross other services.

7.7 SITE SURVEY

The whole of the reservoir site is to be surveyed by a registered surveyor to identify the boundaries, surface contours and existing services.

This information is to be used by the designer in siting the reservoir, considering the operating levels for the reservoir, pipework routes (inlet / outlet, scour, overflow, bypass), flowmeter, water service, power supply and drainage as well as the access roadway and turning areas.

The site survey shall also indicate the proximity of adjoining properties, particularly those which may be impacted upon adversely by the construction and operation of the reservoir.

During the testing phase, accurate survey is to be undertaken and compared to baseline survey prior to filling.

7.8 GEOTECHNICAL

A geotechnical investigation is required to determine ground conditions which will impose requirements on the designer. The designer shall address:

- Reservoir foundations;
- Pipework thrust restraint;
- Access road and hardstand area;
- Mine Subsidence / Settlement issues

The geotechnical consultant is to prepare both a factual and interpretive report which details the investigation and findings.

7.9 ROAD ACCESS

All weather access is to be provided from the closest public road to the reservoir site. Where access from a public road is not available then a suitable access easement shall be created in favour of Hunter Water. The design of the access road shall reflect the size and operating requirements of Hunter Water maintenance vehicles.

The road shall be an all weather sealed road and have a suitable turning area for a 5 tonne maintenance truck or as required for a larger vehicle if nominated by Hunter Water. The minimum road width shall be as stated below with local widening as required at bends. Allowance for the parking of two 5t trucks shall be provided adjacent to the reservoir.

Minimum access road requirements

- Minimum pavement width 3 metres
- Provide access road around full extent of reservoir
- Desirable maximum grade – 12.5%
- Absolute maximum grade – 15% (>15% may be acceptable where concrete pavements are used)
- Preferred crossfall – 3%
- Maximum crossfall – 5%

The access road shall be designed in one of the following materials:

- Flexible pavement with asphalt seal
- Concrete pavement

7.10 HYDRAULIC DESIGN

7.10.1 INLET PIPEWORK

The inlet pipe diameter should be sized for peak instantaneous (all pumps running, no demand) flows and should be one pipe size larger than in the incoming watermain to allow for a future increase in capacity.

A bend / nozzle should be provided on the discharge to promote mixing.

Inlet pipework is to typically be DICL however for steel reservoirs the connection through the floor is to be mild steel welded to the floor plates.

7.10.2 AUTOMATIC INLET VALVES (AIV)

Suitable AIV arrangement will be by electrically actuated valve only, located local to the tank. No AIV is required for direct pumped systems.

The Corporation is to advise where use of fail safe condition of electric actuator is required.

7.10.3 OUTLET PIPEWORK

The outlet pipe diameter should be sized for peak instantaneous (no pumps running, peak demand) flows and should be one pipe size larger than in the discharge watermain to allow for a future increase in capacity.

The outlet should nominally be located close to the centre of the reservoir. The outlet pipe is to be positioned at a height to minimise the risk of any accumulated sediment within the reservoir being disturbed and being discharged during reservoir operation. This is typically achieved by positioning the outlet above the designed grade of the reservoir floor, normally graded to achieve a minimum 100mm fall.

Outlet pipework is to typically be DICL however for steel reservoirs the connection through the floor is to be mild steel welded to the floor plates.

7.10.4 OVERFLOW

A vertical pipe located outside the reservoir (where possible) with a suitable inlet arrangement set at an appropriate invert level would form the outlet structure.

The overflow pipe diameter should be sized for peak instantaneous (all pumps running, no demand) flows and sized to prevent excessive velocities. The overflow pipe is normally one size large than the inlet pipeline.

Provide a bellmouth on the overflow, situated a minimum 200mm above TWL with minimum of 300mm freeboard between top of bellmouth and underside of roof members. Ensure that the bellmouth is free of obstruction from roof members.

Undertake a risk based assessment of time for overflow due to response times, telemetry backup, asset criticality and location. Consideration is also to be given to instrumentation time delays, accuracy and sensor calibration when selecting operating levels.

To ensure the overflow is always operational there not to be valves on the overflow line.

Overflow pipework is typically DICL. For fabricated steel reservoirs the connection through the wall plates shall be mild steel welded and the overflow pipework components are to be protected using the internal solventless epoxy coating system.

Attachments and fixings for all internal components of the overflow pipework are to be grade 316 stainless steel.

The overflow line shall discharge to an energy dissipation pit or other approved location.

Provide a visual overflow level marker at the roof entry hatch.

7.10.5 SCOUR / WASHOUT BULKHEAD

A washout bulkhead is to be installed in the wall strake of fabricated mild steel reservoirs adjacent to the overflow pipe as per attached drawing RES-108. The scour point in concrete tanks is to be located as to optimise scour and cleaning activities.

A suitably sized scour pipe would extend from the external side of the bulkhead or scour point to an energy dissipation pit or other approved location.

The scour pipeline is to be as a minimum, the same diameter as the inlet pipe and will generally connect through a valved connection to the overflow line.

An external pit shall be provided in the scour line to allow sludge to be trapped and pumped out.

7.10.6 WASHDOWN HYDRANT

A spring hydrant connection for manual washdown is to be located in the access road close to the main personnel access hatch. The supply for this hydrant shall be a DN100 pipeline connected to the upstream side of the inlet pipeline valve.

This hydrant will be used for manual washdown.

Allow for installation of the hydrant internally on concrete tanks and externally for mild steel fabricated tanks. Allow for valved connection of a booster for clean out.

7.10.7 SITE DISCHARGE STRUCTURE

An energy dissipation pit is required to reduce the energy of the overflow/scour discharges due to the driving head of the reservoir water level.

Other discharge locations may be acceptable subject to approval by HWC, such as local stormwater reticulation, stormwater channel, sewer manhole etc.

Assess the impacts to both upstream and downstream receiving water including flooding and contamination due to both controlled and uncontrolled discharges for the chosen option.

Ensure retention of sediment and sludge within a pit.

7.11 WATER QUALITY ASPECTS

7.11.1 MIXING OF STORAGE

Stagnant areas within the reservoir can lead to microbiological growths, which may be difficult to control. Based on the size of the proposed storage (<10ML), mechanical mixing is not normally required where provision of separate inlet and outlet pipework / nozzles are used. The arrangement for a circular reservoir will be a tangential inlet and a central outlet arranged so that the inlet and exit energy maintains rotation of the water in the reservoir (i.e.

a dynamic volume is created). Direct inlet nozzle to maximise mixing of the reservoir. Normally the acceptable criteria for reservoir turnover would be at least once per day.

For large reservoirs (>10ML), CFD (Computational Fluid Dynamics) analysis is required to determine whether adequate mixing / contact time can be achieved without use of a submersible mechanical mixer.

7.11.2 VENTILATION / VERMIN PROOFING DETAILS

The Australian Drinking Water Guidelines (ADWG) stress the importance of securing the distribution system and it is recommended that the following measures should be incorporated into the design.

While no ventilation is the ideal for water quality, it is desirable / good design practice to provide sufficient natural some ventilation to limit corrosion of the roof structure and assist in minimising OHS risks during confined space entry. This can be achieved by a combination of inlet ventilation openings provided at the top of the wall strake together with ventilators located at the centre of the roof structure.

Ventilators shall be designed to allow for air to be discharged during reservoir filling and for 6 air changes per hour based on the air volume above TWL. Normally turbine ventilators are installed (refer drawing RES-105), consideration should be given to use of fixed ventilators in high wind areas.

To guard against the entry of contaminants, for example birds and small animals, all ventilation openings will be covered with a vermin proof mesh consisting of corrosion resistant materials (marine grade aluminium or stainless steel).

Provide a ventilation access hatch in bottom wall strake to enable forced ventilation for future maintenance / coating application.

7.11.3 INLET NOZZLES

Normally separate inlet / outlet pipework to the reservoir is required. Where the Corporation accepts a common inlet / outlet pipework arrangement, provide a Hydraulic Enhancement Nozzle (HEN) complete with dual flap gate on the inlet pipework to assist with mixing.

The HEN is normally constructed of HDPE and is to incorporate grade 316 stainless steel diver safety bars.

7.11.4 RE-CHLORINATION

Determine in conjunction with the Corporation whether a site specific chlorination facility is required to boost disinfection levels within the system.

Where required ensure that adequate land area is available for operation and maintenance of the facility.

7.11.5 STORMWATER MANAGEMENT DETAILS

Design the roof structure to allow the rainwater to flow off the roof to the hardstand area below around the reservoir and be managed using a network of site drainage pits and pipes.

Detail site drainage so that it provides adequate protection to the access road, reservoir and surrounds and also complies with local Council or other authorities requirements.

Ensure all roof water drains off the reservoir, full length sheeting is to be used where practical and laps of roof sheeting to be in accordance with the manufacturer's recommendations. Gutters should not be used as the accumulation of leaves can permit

entry of contaminants into the reservoir. Ensure hatches are designed to prevent the ingress of water run-off.

7.12 BOUNDARY FENCING

Reservoir site boundaries are typically unfenced. Where a site boundary fence is required, provide a lockable 4m wide access gate and an additional personnel access gate. Other site security may be required for some locations and Hunter Water is to be consulted as to their requirements for each site.

Incorporate the HWC standard boundary fencing requirements in the design where required (refer drawing RES-113).

7.13 LANDSCAPING

Ensure that the aesthetics of the area are maintained and prepare a landscape plan that addresses this issue as part of the design drawings and specification. The landscape plan shall be designed to blend into the local area and be determined on lowest cost for ongoing maintenance.

Choices of flora shall be suitable to the area. Trees and shrubs are to be Australian natives. If the reservoir is within a public reserve or crown land then the local Council shall be consulted to identify appropriate types of planting and any other specified requirements.

No planting over services or under powerlines is allowed and special attention shall be paid to the type of trees and shrubs planted in the vicinity of pipework. Consideration shall also be given to the location of plants.

Hunter Water guidelines for planting can be found in Hunter Water Corporation's website:

<http://www.hunterwater.com.au/docs/reports/TreeRoots.pdf>

7.14 DESIGN LIFE

Design service life requirements are shown in the following table:

Table 3 Asset Design Life

Component	Minimum Service Life assuming maintenance is carried out
Steel Reservoir	75 years
Concrete Reservoir	75 years
Rafters and Columns	40 years
Purlins	25 years
Roof Sheeting	25 years
Pipework	50 years
Mechanical Equipment	25 years
Electrical Equipment	15 years
Cathodic Protection System	20 years

7.15 WHOLE OF LIFE COSTS

Where requirements nominated in this document allow a choice in the type of reservoir type, arrangement or materials of construction, the final choice will normally be determined by the most cost-effective method. Cost effectiveness should be determined by a net present value analysis.

Factors to be considered are:

- Cost of reservoir structure.
- Access and maintenance costs.
- Life and replacement cost of coatings, roof and including ancillary items such as switchgear, telemetry, ventilation equipment etc.
- Discounted energy cost over the life of the reservoir (Only where mixers are required).
- Net present values (NPV's) of alternatives.

7.16 DURABILITY

Adopt the following material selection criteria to ensure long term integrity, to minimise / eliminate material degradation and the need for ongoing maintenance.

Table 4 Coastal Tank Material Requirements (<5km from coast)

Element	Steel Reservoir	Concrete Reservoir
Walls	250MPa Mild Steel Plate	Concrete 40MPa (min)
Floor	250MPa Mild Steel Plate	Concrete 40MPa (min)
Rafters	Galvanised Mild Steel	Galvanised Mild Steel or Extruded Marine Grade Aluminium Alloy (Z beams)
Purlins	Seasoned Hardwood Timber or Roll Formed Marine Grade Aluminium (C-Profile)	Seasoned Hardwood Timber or Roll Formed Marine Grade Aluminium (C-Profile)
Roof Sheeting	Aluminium Alloy 5251 (Min 0.9mm)	Aluminium Alloy 5251 (Min 0.9mm)
Roof Access Platform	Marine Grade Aluminium	Marine Grade Aluminium
Roof Access Covers	Marine Grade Aluminium	Marine Grade Aluminium
Internal Ladder	N/A	316 Stainless Steel / FRP / GRP
External Stairs	Marine Grade Aluminium	Marine Grade Aluminium
Columns	Mild Steel CHS	316 Stainless Steel or Reinforced Concrete
Handrails	Marine Grade Aluminium	Marine Grade Aluminium
Pipework	DICL / MSCL	DICL / MSCL

Table 5 Inland Tank Material Requirements (>5km from coast)

Element	Steel Reservoir	Concrete Reservoir
Walls	250MPa Mild Steel Plate	Concrete 40MPa (min)
Floor	250MPa Mild Steel Plate	Concrete 40MPa (min)
Rafters	Galvanised Mild Steel	Galvanised Mild Steel or Extruded Marine Grade Aluminium Alloy (Z beams)
Purlins	Seasoned Hardwood Timber or Roll Formed Marine Grade Aluminium (C-Profile)	Seasoned Hardwood Timber or Roll Formed Marine Grade Aluminium (C-Profile)
Roof Sheeting	Aluminium Alloy 5251 (Min 0.9mm)	Aluminium Alloy 5251 (Min 0.9mm)
Roof Access Platform	Marine Grade Aluminium	Marine Grade Aluminium
Roof Access Covers	Marine Grade Aluminium	Marine Grade Aluminium
Internal Ladder	N/A	316 Stainless Steel / FRP / GRP
External Stairs	Galvanised Mild Steel	Galvanised Mild Steel
Columns	Mild Steel CHS	316 Stainless Steel or Reinforced Concrete
Handrails	Galvanised Mild Steel	Galvanised Mild Steel
Pipework	DICL / MSCL	DICL / MSCL

7.16.1 THERMAL EFFECTS

Roof sheeting designs are to incorporate sliding joints or similar to allow for thermal effects.

All aluminium roof structures designs are to incorporate sliding connections with slotted holes to allow for thermal effects.

7.16.2 DISSIMILAR METALS

All points of contact between materials are to be separated by isolating mediums, with the exception of Aluminium and Stainless Steel.

7.17 PREFERRED EQUIPMENT LIST

Hunter Water has approved products and manufacturers for equipment used in water supply and associated electrical works. These are listed on Hunter Water's website under www.hunterwater.com.au. This lists approved equipment able to be used for installation in Hunter Water's water pumping stations.

In most cases, specific equipment is not nominated in specification documents except where reasons exist that a particular brand or model must be used. As such, the designer would need to justify this with Hunter Water.

Reference to the listing of approved products and manufacturers is to be incorporated in the Technical Specifications.

7.18 STRUCTURAL DESIGN

7.18.1 FABRICATED MILD STEEL

Design the reservoir to meet the following:

- AWWA D100-05 Section 14 using API 650 variable point design method;
- Roof and associated columns and supports to AS4100;
- Wind load to AS1170.2;
- Earthquake load design to AS1170.4 and NZS 3106;
- AS1170.0-2002 Structure design actions;
- AS1170.1-2002 Structure design actions Part 1 Permanent, imposed & other actions;
- AS 1657-1992 Fixed platform, walkway and ladder loads
- AS 5100.5 Non- water retaining concrete elements
- Mild steel plate for reservoir shell and floor to AS 3678 (Grade 250 only)
- Mild steel sections for roof structure, supports, and platforms to AS3679 (Grade 300)
- Mild Steel columns to AS1163 (Grade 350)

In addition, the following parameters shall be incorporated into the wall and floor plate design:

- Corrosion allowance of 2mm for all plate
- Design limiting stress for base bending up to 0.5 x Yield Stress is considered acceptable.
- The maximum additional horizontal deflection due to filling shall be the lesser of height/250 and 20mm.
- Careful handling methodologies / procedures are to be developed and employed on-site to minimise plate buckling / deformation.

The Design Report should include as a minimum the method of calculation of the steel shell, hoop stress in the walls, bending stress in the floor to wall joint and wall deflections.

7.18.2 REINFORCED CONCRETE TANKS (CAST IN-SITU & PRE-CAST)

Design the reservoir to meet the following:

- AS3735 Concrete Structures for Retaining Liquids;
- AS3600 Concrete Structures;
- Other relevant standards include AS1012.3, AS1012.4.1, AS1012.4.2, AS1012.4.3, AS1012.3 , AS1141.5, AS1141.6.1, AS1141.6.2, AS1302, AS1303, AS1304, AS1478, AS3582, AS3972, AS1379, , AS2758.1 and AS3610;
- Roof and associated columns and supports to AS4100;
- Wind load to AS1170.2;
- Earthquake load design to AS1170.4 and NZS 3106;
- AS1170.0-2002 Structure design actions;
- AS1170.1-2002 Structure design actions Part 1 Permanent, imposed & other actions;
- AS 1657-1992 Fixed platform, walkway and ladder loads; and
- AS 5100.5 Non- water retaining concrete elements.

In addition, the following parameters / considerations shall be incorporated into the design:

- Minimum steel for crack control
- Concrete mix design
- Minimise shrinkage effect by pouring the sections of the work between construction joints in a sequence such that there will be suitable time delays between adjacent pours.
- Curing methodology

- Single reinforced concrete structural elements are not permitted. Minimum wall thickness of double reinforced structural elements to be 230mm wide.
- Concrete pour heights for vertical elements to be minimised to prevent segregation
- Jointing and sealing methodology

7.18.2.1 Cast In-Situ

Where approved by the Corporation, use of reinforced cast in-situ concrete construction method is acceptable where whole of life costs are considered.

Additional site surveillance is normally required to ensure quality is maintained in terms of slump, cover to reinforcement, stability of formwork, testing regime, water seals, placement, monitoring use of admixtures and water cement ratio etc.

7.18.2.2 Pre-Cast Post Tensioned

Where approved by the Corporation, use of pre-cast concrete post tensioned construction methods is acceptable where whole of life costs are considered.

Additional detail design and construction requirements are normally required to ensure quality is maintained in terms of precast panel design, joint interfaces, tensioning, stitch panel, etc.

7.18.2.3 Concrete Mix Design Requirements

Use Type SR to AS 3972 and containing 25% fly ash (as cement substitute) to AS 3582 Part 1 (fine grade only). Silica Fume may also be used in lieu of fly ash.

Table 6 Concrete Mix Requirements

Requirement		S40	N25
		Type 1	Type 2
Materials and Mix	Cement Type	SR	GP
	Minimum cement kg/m ³	380	-
	Maximum cement kg/m ³	410	-
	Fly ash (or silica fume) used as cement substitute	25%	-
	Maximum W/C Ratio	0.45	-
	Project specific laboratory trial mix required from plant where concrete for the structure is to be supplied from Yes / No	Yes	No
	Supply grading curve for mix design Yes / No	Yes	No
Characteristic Strength (MPa)	Compressive f'C 28 days	40	25
Other	Nominal slump (mm)	80	-
	Drying shrinkage (3 weeks)	500 x 10 ⁻⁶	-

Drying shrinkage (Max. @ 59 days)		700 x 10 ⁻⁶	
Total alkali reactive content (Not greater than)		3.0kb Na ₂ O / m ³	
Air content %		-	-
Surface finish		See Clause 'Concrete Finishes'	
Pumped concrete accepted	Yes/No	Yes	Yes
Minimum period between adjacent pours (days)		3	-

Type 1: All liquid retaining structures, including any lining used as watertightness barrier.

Type 2: Footpaths, thrust blocks, concrete encasement, plug concrete, blinding concrete and concrete kerbs.

7.18.2.4 Aggregates

Aggregates used in the manufacture of concrete shall be of clean hard, chemically inert and durable particles that comply with AS2758.1 for an exposure classification 'C' and comprise either normal weight or heavy weight aggregates.

The water absorption of aggregates shall not be less than 3% when tested in accordance with AS1141.5, AS1141.6.1, AS1141.6.2.

The alkali reactivity of the aggregate shall be assessed to clause 10 of AS2758.1.

7.18.2.5 Addition Of Water

Water used in the manufacture of concrete shall be of good quality complying with AS1379.

7.18.2.6 Chemical Admixtures

Admixtures that enhance the workability, reduce water cement ration, control slump, minimise shrinkage and control the setting time of the concrete may be included in the mix in a controlled manner, provided they have been proven to not impair the performance of the concrete.

Air entraining admixtures may be used provided that the air content, determined in accordance with AS1012.4.1, AS1012.4.2 or AS1012.4.3 does not exceed 4%.

Admixtures shall comply with AS1478.

7.18.2.7 Cover Requirements

Provide the following minimum concrete cover to reinforcement:

Table 7 Minimum Concrete Cover

Location	Concrete Cover
Air face	50
Water face:	65
Ground face:	
(a)Against a polyethylene membrane or blinding concrete	50
(b)Directly in contact with the ground	65

7.18.2.8 Joint Sealing

Provide PVC waterstops for all cast in-situ joint interfaces. Hydrophilic, mastic type, waterstops shall not be used.

Interfaces between pre-cast sections or between pre-cast and cast in-situ to be detailed on the design drawings. Refer to drawing RES-115 for floor to wall joint standard arrangement.

Where joint sealing is to include a primary and secondary seal, watertightness test is to be completed and passed prior installation of secondary seal.

7.18.2.9 Concrete Repairs

Repair all air voids, bolt holes and honeycombing using a suitable epoxy mortar applied strictly in accordance with manufacturer's instructions.

Repairs by bagging using cement mortar etc will not be permitted. Submit a work method statement to the PAP for approval 48 hours prior to undertaking repairs.

Other repair methodologies may be acceptable, subject to approval such as injection methods.

7.18.2.10 Watertightness Test

Filling methodology of liquid-retaining structures with first water is not to exceed a uniform rate, generally not greater than 2 m in 24 h to the top of the structure to test for watertightness.

When first filled, the liquid level is to be maintained by the addition of further liquid for a stabilizing period of 7 days while absorption and autogenic healing takes place. After the stabilizing period, the level of the liquid surface shall be recorded at 24 h intervals, for a test period of 7 days. During this 7-day test period, the total permissible drop in level, after allowing for evaporation and rainfall (if the test is made for an uncovered structure) shall not exceed 1/500th of the average water depth of the full tank or 10 mm, whichever is less.

Determine evaporation during testing period by direct measurement of evaporation losses in a manner approved by the National Association of Testing Authorities.

7.18.3 BOLTED STEEL TANKS

Bolted steel tanks are not acceptable except for shorter design life applications such as 15 years.

7.19 ROOF ACCESS

7.19.1 ROOF ACCESS STAIRS

Roof access shall be provided for all reservoir types. This shall be done via a free standing fabricated stairs / platform structure in lieu of caged ladder system to reduce OHS risks to operations and maintenance personnel.

Provide a security enclosure around perimeter of stair access (refer drawing RES-114). Ensure that electrical switchboard is located within the security fenced area.

Vertical ladders are not acceptable to the Corporation.

7.19.2 ROOF PLATFORM

For concrete tanks, the reservoir roof platform (at top of the roof for access into the reservoir) shall be located directly over the traffic accessible area in order to enable the maintenance operator to use the davit to pick up equipment from a vehicle below (refer drawing RES-109 for davit details)

The roof platform is to be constructed of marine grade aluminium.

For concrete tanks, the roof platform shall be large enough to provide for the hatch cover and lifting davit. There shall be sufficient room on the platform when the cover is open for adequate access to the cover and ladder with a minimum unobstructed flat area of 1,500 mm x 3,000 mm,

The roof platform is to have a handrail on its perimeter.

A gate shall be provided in the handrail to give access to the peak of the roof. The gate will be used for a person to access the roof, walking in a straight line to the peak, where a lanyard attachment will be located for the person to latch on to – all the while the person is protected from falling off the roof by the handrails around the roof platform. (Refer drawing RES-102 and -05).

7.19.3 MAINTENANCE ACCESS VEHICLE HATCH

For tanks greater than 30m diameter provide a vehicle hatch minimum dimension 4000mm x 2000mm to be installed on the roof to allow a bobcat or similar to be lowered into the tank.

Hatch cover to be hinged operated and lockable when cover is at an open or closed position. Provide mechanical means of opening, hand operated winch or similar.

7.19.4 ROOF ACCESS HATCH

Provide a lockable hatch cover over the internal ladder (no internal ladder is required for a steel reservoir but the hatch cover position shall be similar to a concrete reservoir).

Hatch cover to be hinged operated and lockable when cover is at an open or closed position. Provide mechanical means of opening, hand operated winch or similar, for heavy hatches covers or hatches covers positioned with restricted access.

For concrete tanks provide two means of entering the structure by access hatches.

7.19.5 INTERNAL LADDER

Provide an internal ladder (for a concrete reservoir only) extending from the Roof Platform to floor level. Material for the internal ladder shall be either stainless steel Grade 316, FRP or GRP. The ladder shall have either extended handrails or similar system to orientate person(s) descending or ascending.

Provide a suitable fall arrestor system where the potential fall from height exceeds legislated limits or risk assessment justifies provision of such a system. Design the attachment point for the Lanyard (Life Line) in such a way to allow a person to be attached before entering the hatch area. The ladders and fall arrest systems must be compliant with AS1657 Fixed Platforms, Walkways, Stairways and Ladders and AS/NZS1891 Industrial Fall Arrest Systems and be clearly marked with the safe working load.

Refer drawing RES-103.

7.19.6 EYEBOLTS

Where required, all load bearing components / attachments to be load tested as per AS1891.

Eyebolts are to be properly secured on a central post to enable maintenance personnel to attach Lanyards (Life Lines) and to work around the reservoir roof and wall (refer drawing RES-102 and -05).

Provide two (2) eyebolts for each opening in the roof. Locate eyebolts approximately 1,600 mm from the centre of the opening to suit 1,800 mm long lanyards / life lines and to secure the harness worn by the stand-by personnel.

Provide a minimum 35mm hole for eyebolts to enable attachment of lanyards / life lines.

7.19.7 DAVIT AND LIFTING GEAR

The davit and lifting gear is to be made from galvanised steel (refer drawing RES-109).

Provide for a manually operated winch (for a concrete reservoir only) that can be attached to the davit arm. The davit and lifting gear shall be hand operated and designed to comply with the following minimum requirements:

- The centre of the lifting gear shall be above the centre of the opening for the hatch cover,
- Ground unloading point shall be at least 600 mm away from objects (i.e. handrails, posts, roof and wall),
- The davit shall be capable of unloading a person on the Roof Platform (i.e. within the handrails, not on the roof),
- Lifting gear shall be sufficient to pick up load from the floor of the reservoir and unload on the ground outside the reservoir,
- There shall be a minimum 2.4m clearance above the roof or platform level to the jib,
- The davit shall have an eyebolt or similar device to enable easy detachment of the lifting gear,
- The davit shall have a handle or other device to facilitate slewing by hand,
- The davit shall have a maximum horizontal force to comply with the standard / regulations,
- The davit shall have a minimum safe working load capacity of 1.5 Tonne,
- The davit shall have a maximum deflection (vertical) 10mm.

The ground landing area shall be an unobstructed flat horizontal area of minimum horizontal dimensions 6000 mm x 2000 mm and shall be so positioned in relation to the reservoir wall in order to enable unloading at the approximate centre of the area.

7.20 WALL STRAKE ACCESS (FABRICATED STEEL ONLY)

7.20.1 PERSONNEL ACCESS HATCHES

For steel reservoirs a minimum of two wall strake personnel hatches are to be included, located opposite one another. Personnel hatches are to be 1100mm wide by 1800mm high, to allow both personnel access and access for a small excavator "Dingo" or equivalent. (Refer drawing RES-106)

7.20.2 VENTILATION HATCH

For steel reservoirs a 600mm diameter ventilation hatch shall be provided to provide allow forced ventilation to be provided. This is primarily required when painting the internal surfaces. (Refer drawing RES-107)

This ventilation hatch ensures that trip hazards are removed from main personnel access hatch areas.

7.21 STEEL FLOOR PLATES

The floor shall be graded from the centre to the outside of the reservoir at a grade of 1% (i.e. for tanks < 10ML).

Annular plates are to be used for wall / floor connection stresses.

For annular plates and floor plates which are to be in contact with the ground, apply 75microns DFT of inorganic zinc up to a minimum of 1000mm from the reservoir perimeter.

7.22 COLUMNS

The number of internal columns should be kept to a minimum. Where possible the roof structure should be designed with only a central column.

Align plates to ensure columns are located in areas free of joints.

For steel reservoirs roof support columns shall be painted with the same internal coating system as the walls and floor.

For concrete reservoirs roof support columns shall be 316 stainless steel bolted to the concrete floor slab or be constructed of reinforced concrete.

7.23 SAMPLING ARRANGEMENT

Incorporate sampling point arrangement as shown on drawing RES-110

7.24 RESERVOIR TESTING

7.24.1 GENERAL

The reservoir shall be tested in accordance with an approved detailed testing procedure. This procedure shall be submitted to HWC for approval prior to testing. The details of the testing procedure shall be based upon the following considerations:

- Ensure that testing water can be removed quickly and safely from the reservoir if required.
- Ensure that foundation settlement behaviour is within predicted limits.
- Ensure there is no leakage and that the reservoir is fit for service.

The following requirements shall be incorporated into the detailed testing procedures as appropriate.

7.24.2 MILD STEEL FABRICATED TANKS

7.24.2.1 Floor Testing

The floor of the reservoir shall be tested for leaks either by:

- Vacuum testing using a vacuum box and a pressure of 650 mbar absolute (i.e. 350 mbar of vacuum).
- 100% magnetic particle examination to AS1554.1, with no cracking or porosity permitted.

7.24.2.2 Wall Testing

The reservoir shall be tested by filling with water to the normal operating top water level.

The rate of filling shall be controlled and managed to minimise loading to the tank.

The full exterior of the reservoir, including all mountings shall be continuously inspected during the water testing, for the presence of leakage. If leakage is detected, filling shall cease immediately and an approved method of repair shall be completed prior to recommencement of the testing. The water level shall be lowered to an approved "safe" level prior to carrying out any repair work. This "safe" level shall be at least 600 mm below the area of repair.

The level of the top water surface shall be monitored for the holding period of 48 hours. If the water level falls during this period, then the water level shall be held for a further 48 hours. If a further drop in water level is detected, an approved procedure for leakage detection and repair shall be immediately instigated.

7.24.3 FOUNDATIONS

The load / settlement behaviour of the foundations shall be carefully monitored during the water testing phase by accurate survey compared to baseline survey prior to filling.

If the total settlement at any control point exceeds 10 mm or the differential settlement between any two adjacent control points on the perimeter exceeds 5 mm, then filling shall be immediately terminated and the testing procedure shall be modified or abandoned.

All survey work associated with testing shall be carried out by an independent registered surveyor, with a report summary of results presented to HWC on completion.

7.24.4 HYDROSTATIC TESTING

Prior to testing, the tank shall be thoroughly cleaned.

At the completion of testing, the test water shall be returned to supply or allowed to drain to the scour line.

The Corporation shall approve the intended method of water disposal prior to emptying the tank or putting it into service. The Corporation will be responsible for addition of chlorine tablets or similar to ensure effective chlorination of the tank prior to putting into service.

7.24.5 OVERFLOW / SCOUR

The operation at the overflow and scour systems shall be tested using a HWC approved procedure. Care shall be taken to ensure that no damage is caused to the reservoir or the environment.

7.25 COATING SYSTEMS FOR FABRICATED STEEL TANKS

7.25.1 GENERAL

Protection of fabricated carbon steel components is required for all reservoirs. All work is carried out in a competent manner by personnel experienced in application of the painting systems.

All coatings are to be applied on-site with provision for full encapsulation.

7.25.2 SURFACE PREPARATION

7.25.2.1 Procedure

All surfaces to be protective coated using solvent-less high build epoxy shall be blast cleaned to give a Class 3 – “White Metal” standard of surface preparation in accordance with AS1627.4.

The maximum surface profile height shall not exceed one-third of the dry film thickness of the coating system. The minimum profile height shall be as recommended by the coating manufacturer.

All surfaces to be protective coated shall be free from rust, mill scale, oil, grease, dust or other contaminants and shall be thoroughly dry and clean.

All irregularities on the surface, including weld spatter, welding slag etc shall be removed by grinding flush prior to blasting.

Sharp edges shall be rounded (radius not less than 10 mm) before blasting.

Blast-cleaned surfaces shall be coated as soon as possible and shall be coated before any discoloration occurs. At no stage shall a blast-cleaned surface be permitted to stand overnight without being coated. If flash corrosion does occur, the surfaces shall be re-blasted to the specified class of surface preparation.

7.25.2.2 Abrasive Material

The abrasive medium shall be:

- Silica-free.
- Clean and dry.
- Free from contaminants such as dirt, clay and organic matter.
- Free of chloride contamination.
- Free of soluble copper.
- Free of metallic copper.

The Contractor shall take all necessary precautions to ensure that blast grit is effectively contained and removed promptly from site. Implement additional site protection measures as directed by the Superintendent, to ensure that site blasting operations do not adversely impact the surrounding environment and meet environmental requirements.

7.25.3 COATING MATERIALS

All coating material containers shall bear the manufacturer's label, batch number, instructions for application and date of expiry where applicable. Keep written records of batch numbers and provide to HWC.

7.25.3.1 Reservoir Internal Surfaces

The coating for all internal surfaces subject to submergence including, walls, floor, pipework and access door shall be two (2) coats of a high build solvent-less epoxy, each coat consisting of a minimum DFT (Dry Film Thickness) of 250 microns. Each coat is to be a different colour, the finish coat colour shall be white. Each coat shall be applied to the whole reservoir in one continuous coating before starting the next coat.

If a holder primer is needed, the tank is to be completely washed out prior to application of finish coats.

7.25.3.2 External Surfaces (Coastal Tank <5km To The Coast)

The coating for the reservoir external surfaces is to be a zinc epoxy to manufacturer's requirements with a solvent borne acrylic as the topcoat also to manufacturer's requirements.

External colour is normally 'colorbond' mist green, final selection to be confirmed by the Corporation.

7.25.3.3 External Surfaces (Inland Tank >5km To Coast)

The coating for the reservoir external surfaces is to be two (2) coats of an inorganic zinc silicate to a minimum dry film thickness of 75microns per coat.

While preference is for the inorganic zinc finish, where site aesthetics are required, apply an additional coating of solvent borne acrylic topcoat to manufactures requirements.

7.26 CATHODIC PROTECTION (CP) SYSTEM

7.26.1 GENERAL

Design of sacrificial anode CP systems is to be done by a specialist to ensure a corrosion protection system which will provide protection of the fabricated steel reservoirs over an extended period (20+ years).

Normally reservoirs with submersible mixers require design of an impressed current system.

The CP system would normally comprise the following:

- Magnesium anode strings suspended from the roof using plastic inserts.
- Permanent copper/copper sulphate reference electrode strings also suspended from the roof using plastic inserts.
- CP junction box containing a test panel (test point) external to the reservoir. The desired position of the test panel on the roof of the reservoir.
- Conduit and cabling to run from the anode strings and electrode strings on the roof of the reservoir to the test point and from the reservoir wall to the test point.
- Ensuring insulation and isolation of all reservoir internal components / equipment.

7.26.2 LOCATION OF FACILITIES

Anode roof holes are normally 80mm holes located one third of the distance from the reservoir wall to the centre, with each hole equidistant from each other around the reservoir roof.

Electrode roof holes normally 40mm diameters are to be located adjacent to the reservoir walls. One should be located adjacent to the access hatch, and the other located on the opposite wall.

Locate a test point adjacent to the external ladder on an upstand or existing handrail.

7.26.3 ANODES

Provide for magnesium high potential anodes to AS 2239-1993, normally of dimensions 50mm x 50mm x 1500mm, supplied with 6mm² single core copper PVC insulated cable tails. The cable tails shall extend from the anodes to the roof junction box without cable joints.

Anode holes shall be fitted with stainless steel cathodic protection enclosures consisting of a 250mm x 200mm x 150mm box with 1 off 100mm diameter hole drilled in side panels plugged with 2 off 25mm conduit plugs supplied complete with 1 x 100mm PVC cap with a 12mm hole drilled in end and complete with lockable handle.

The anode holes shall be fitted with UPVC inserts. Each UPVC insert shall be made as follows:

- Use two sections of UPVC; one of 70mm diameter and one of 180mm diameter, 10mm thick. Fix the two sections together concentrically by gluing.
- Provide a stainless steel grade 316 support hook in the centre of the insert. A stainless steel nut and washer on the top surface of the insert shall fix the support hook.
- Insert two cable glands in the insert.
- Ensure assembly is sealed to prevent ingress of rain water to the reservoir.

The anodes shall be suspended from the anode hole inserts. In each hole anodes shall be located equidistant from each other with the lowest anode 0.5 metres from the floor. The top of the highest anode shall be approximately 5 metres from the floor. The anode tails shall be fixed together with cable ties.

The anode tails shall be fixed to the support hooks, and the support arrangement shall be so designed as to provide support under robust water loading over a period of 20 years without damage to the cable or slippage of the anodes.

The anode cables shall be run through the cable glands that shall be tightened appropriately.

On the top of each UPVC insert the four anodes shall be electrically bonded and connected to a 6mm² single core copper PVC insulated cable to the test point. The bonding shall be with crimp links and housed within a UPVC junction box.

The crevice between the UPVC insert and the top surface of the roof shall be sealed with a silicone sealant.

7.26.4 ELECTRODES

Copper/copper sulphate permanent reference electrodes suitable for permanent fresh water immersion are required. The electrodes tails shall extend from the electrodes to the roof junction box without cable joints.

The electrode holes shall be fitted with UPVC inserts. Each UPVC insert shall be made as follows:

- Use two sections of UPVC; one of 30mm diameter and one of 130mm diameter, 10mm thick. Fix the two sections together concentrically by gluing.
- Provide a stainless steel grade 316 support hook in the centre of the insert. A stainless steel nut and washer on the top surface of the insert shall fix the support hook.
- Insert two cable glands in the insert.

The electrodes shall be suspended from the electrode holes and the electrode tails shall be fixed together with cable ties.

Alternative means of support will be considered but must be submitted for approval with sufficient written case history from previous applications.

Both electrode strings shall have the bottom electrode located with its bottom 0.5 metre from the floor and the other with its bottom 4 metres from the floor. A nylon rope shall be run with the electrode cables and fixed to them with cable ties. A 1kg zinc weight of dimensions 25mm x 25mm x 200mm shall be fixed to the bottom of the rope with its bottom 200mm from the floor.

The electrode tails, and support rope on one string, shall be fixed to the support hooks, and the support arrangement shall be so designed as to provide support under robust water loading over a period of 20 years without damage to the cable or slippage of the anodes.

The electrode cables shall be run through the cable glands tightened appropriately.

On the top of each UPVC insert a UPC junction box shall be installed. If any cable connection is required in the cable run from the electrode to the test point, it shall be made in the junction box.

The crevice between the UPVC insert and the top surface of the aluminium roof shall be sealed with a silicone sealant.

7.26.5 TEST POINT

The test point shall comprise an aluminium or stainless steel grade 316 junction box located as per clause 'Location of Facilities'. Alternative support arrangements may be considered by the Corporation.

Within the junction shall be an insulated panel containing as a minimum; terminals for the six anode strings, the reservoir connection and the four reference electrodes. Shunts shall be installed in each of the anode string connections. The anode string connections shall terminate on a copper bus to which the reservoir connection is also connected.

All cables shall be labelled with crimp on markers. All terminations and functions on the test point panel shall be provided with appropriate labelling, including the rating of the shunts.

7.26.6 CABLING

All cabling on the roof shall be run in flexible conduit from the UPVC plastic insert junction boxes to the roof junction box.

One UPVC conduit shall take all cabling from the roof junction box to the test point. The conduit shall be fixed by a suitable method.

7.27 ELECTRICAL

The electrical components of a reservoir installation comprise:

- Incoming power supply
- Switchboard containing metering, main distribution section, PLC and telemetry equipment
- Instruments for reservoir level etc.
- Area lighting and power
- Security system
- Lightning Protection System

7.27.1 POWER SUPPLY

All reservoir sites will be supplied from the local electrical distribution network. Generally a single phase 230V 50Hz supply will be sufficient except for sites with three phase supplied valve actuators.

The Electricity Distributor needs to be consulted at the earliest possible stage in order to make provision for such a connection.

A generator connection changeover switch facility is not required for typical reservoir switchboards.

7.27.2 SWITCHBOARD

The switchboard is to be located outdoors and constructed in accordance with the requirements for outdoor type switchboards as detailed in HWC Standard Electrical Specification STS500.

The switchboard will comprise various compartments and components to serve many functions. The main compartments are as follows:

- Metering of incoming power supply
- Main Distribution section complete with incomer switch, voltmeter/power meter, auxiliary distribution circuit breakers and GPO
- Programmable logic controller (PLC), Telemetry and Instrumentation cubicle

All electrical equipment must be secured behind an internal door fitted with a lock that is "81/3" keyed. However, the electricity meters, all instrument displays, station controls and at least one 230V AC power outlet shall be accessible by opening an external door with pad-lockable handles. All LV equipment requiring operator access such as voltmeter, GPO, light switch and circuit breakers shall be mounted internally and accessible via cut outs in the inner door.

Outdoor switchboards are to incorporate a security system comprising sensors fitted to the external doors. These sensors are to be connected to the PLC and telemetry to raise an alarm as detailed in Hunter Water's specification STS 105.

7.27.2.1 Metering of Incoming Power Supply

This compartment houses the electricity meters which record kilowatt hours. A separate external door shall be fitted to this compartment to provide access to the Supply Authority Meter readers, without providing access to other controls.

Main Incomer Switch and Distribution Section

This provides isolation of the switchboard from the incoming power supply and distributes power to the site auxiliaries such as power points (GPO's), lighting, security system and controls. Single phase switchboards will include a voltmeter and three phase switchboards will include a power meter.

7.27.2.2 PLC Telemetry and Instrumentation Cubicle

This houses the PLC, Telemetry equipment, control power supplies, GPO for technician's use and field wiring terminals. The power supply for the PLC and telemetry equipment will have battery backup.

The Telemetry equipment includes remote/radio telemetry unit (RTU) which is connected to the PLC, a digital radio and an aerial. The RTU forwards and receives radio signals to and from a base station (for example, Gan Gan, Sugarloaf, etc.) which is connected to the Hunter Water SCADA (supervisory control and data acquisition) system.

This system allows for remote monitoring and control of the reservoir. This is achieved by 2-way communication with the station PLC.

The PLC shall be a Schneider M340 type.

Typical SCADA screen page diagrams will be supplied by Hunter Water and marked up by the designer as part of the design documentation for the particular installation.

7.27.2.3 Radio Path Survey

On completion of the Concept Design, the designer is to engage and pay for a Hunter Water approved supplier to undertake a radio survey and from this to nominate a base station, transmit and receive frequencies and remote terminal unit (RTU) number along with antenna direction/bearing to base, antenna mounting height and antenna size.

The designer must then seek approval from Hunter Water for the above.

7.27.3 LEVEL INSTRUMENTS

Each reservoir will include the following level monitoring equipment:

- Hydrostatic type analogue level transmitter with a nominal range of 1.0 bar.
- Abnormal High Level alarm float switch
- Abnormal low level alarm float switch

The analogue level instrument will include:

- Level display on the Reservoir roof
- Level Display on the PLC/Telemetry and Instrumentation Cubicle internal door
- Surge protection unit at each end of the 4-20mA signal cabling

An outdoor electrical panel will be provided on the reservoir roof to house the

- Level display and surge protection
- Field terminals for level instrument and float switches
- Field terminals for security switches on roof access hatches

7.27.4 SECURITY

The Reservoir site will include a security system area in accordance with Standard Technical Specification STS105. The security system is to comprise:

- appropriate HWC padlocks on access gates, hatch covers, valve pit covers and external doors on electrical switchboard cabinets; and
- a switch-operated alarm system including proximity type switches on hatch covers, electrical switchboard doors, reservoir roof hatches, reservoir stair access gate, passive infrared & voice alarm on reservoir near access stairway landing. All security switches shall be individually connected to terminals in the main switchboard in accordance with Hunter Water's specification STS105.

7.27.5 LIGHTING

Provide sufficient lighting for after hours maintenance on:

- Reservoir access stairway and platforms.
- Reservoir security compound area including main electrical switchboard.

External lighting will be operated by a switch on the Distribution section of the site switchboard.

Lighting levels shall be in accordance with the requirements of STS500.

Lighting is not required on the roof of the reservoir.

7.27.6 SITE 230V GPOS

The following 230V general purpose outlets (GPOs) will be provided, with each GPO supplied from a separate earth leakage circuit breaker:

One on the internal door of the Distribution section of the main switchboard

One inside the PLC/Telemetry/Instrumentation Panel for the technician's use

7.27.7 LIGHTNING PROTECTION

Provide Lightning Protection in accordance with the requirements of STS500.

7.28 DESIGN DOCUMENTATION AND DRAWINGS

7.28.1 DESIGN DESIGN

The designer is to prepare a comprehensive designer's report detailing the logic behind the final design. It should cover all requirements included in strategies, preliminary design reports and concept design reports.

The report shall be accompanied with the following:-

- Detailed drawings, calculations and specifications as required for the various components of the system.
- Where applicable, a copy of the radio path survey report
- Where applicable approvals or letters of agreement from stakeholders/regulatory bodies (eg Government Agencies, RTA, Mine Subsidence Board, etc)
- Agreement to easement rights
- Permit to enter land external to development

Prepare all design drawings in accordance with STS911.

7.28.2 ELECTRICAL DESIGN

The electrical design shall include (but not be limited to) the following drawings:

- Incoming supply and PLC I/O
- General arrangement of switchboards
- Power and Control schematics for all equipment
- PLC I/O Schematics for all equipment
- Telemetry
- Instrument loops
- Installation wiring diagrams for each item and instrument type
- Equipment and cabling layouts
- Light and small power layouts
- PLC layout

Standard electric drawings may be obtained from Hunter Water in electronic format. These shall be used as the basis for the design of the specific reservoir project drawing set.

All electrical design drawings shall comply with the requirements of Hunter Water's specification STS904.

7.28.3 OPERATING AND MAINTENANCE

Prepare an information package and provide Operation and Maintenance manuals with the detail design. The information is to be provided to the construction contractor who will then update / complete the required information prior to submitting to the Corporation.

The information package shall be prepared in electronic format and shall include, but is not limited to, the following items:

- Functional description of the Asset, including operating philosophy and any restrictions on use (asset and components)
- Details (make, model etc) of all maintainable items
- Listing of applicable spare parts (inc. OEM part numbers)
- Frequency and maintenance procedures for all maintainable items
- Durability of non-maintainable items
- Design life of all major components (for example roof, access ladders)

APPENDIX A

Tank / Reservoir Standard Drawings

CIVIL DRAWINGS:

- RES-100 – INDEX SHEET
- RES-101 – TYPICAL SITE ARRANGEMENT
- RES-102 – TYPICAL ROOF ACCESS REQUIREMENTS
- RES-103 – TYPICAL INTERNAL ACCESS ARRANGEMENT
- RES-104 – TYPICAL ELECTRICAL SWITCHBOARD ARRANGEMENT
- RES-105 – TYPICAL ROOF ACCESS AND VENTILATION DETAILS
- RES-106 – TYPICAL PERSONNEL ACCESS HATCH REQUIREMENTS
- RES-107 – TYPICAL ACCESS VENTILATION OPENING REQUIREMENTS
- RES-108 – TYPICAL RESERVOIR SCOUR & WASHOUT
- RES-109 – TYPICAL DAVIT ARM ARRANGEMENT
- RES-110 – TYPICAL SAMPLING POINT REQUIREMENTS
- RES-111 – TYPICAL RESERVOIR SIGNAGE
- RES-112 – TYPICAL ENERGY DISSIPATOR ARRANGEMENT
- RES-113 – TYPICAL SITE FENCING DETAILS
- RES-114 – TYPICAL SECURITY FENCING ARRANGEMENT AND DETAILS
- RES-115 – TYPICAL CONCRETE WALL TO FLOOR DETAIL

TANK/RESERVOIR STANDARD DRAWINGS

	HUNTER WATER CORPORATION A.C.N. 053 102 837	STANDARD DESIGN RESERVOIR STANDARD	FILE REFERENCE: HW2009-2368/3/6
0 ISSUE	S.H 17.05.2011	INDEX SHEET	HWCS RES-100
REV No.	REVISION	APPROVED	DATE
© COPYRIGHT HUNTER WATER CORPORATION LIMITED.	APPROVED ASSET STANDARD ENGINEER HUNTER WATER CORPORATION	APPROVED MANAGER ASSET MANAGEMENT HUNTER WATER CORPORATION	ISSUED: MAY 2011
			A.3



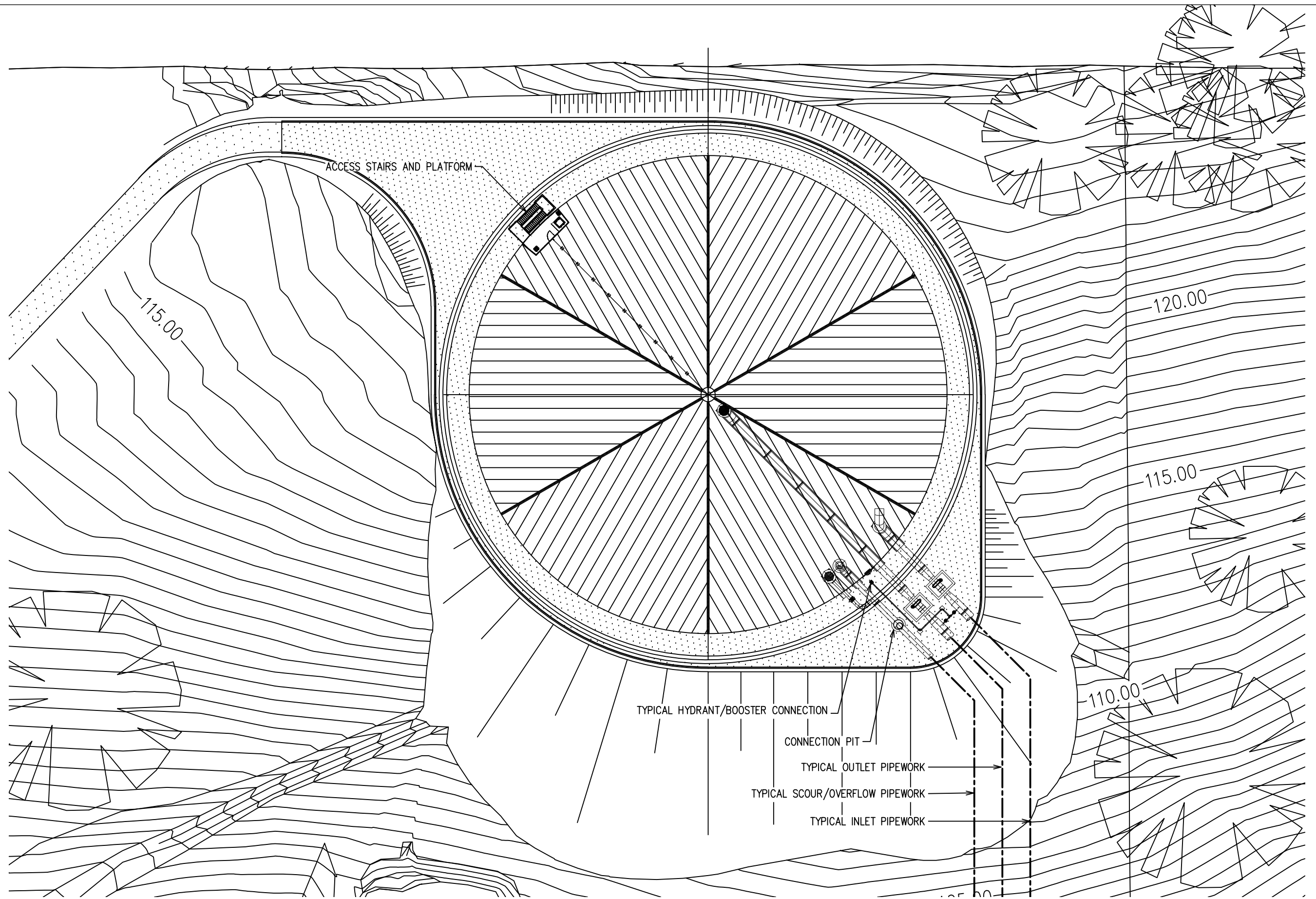

0	ISSUE		S.H	17.05.2011
REV No.	REVISION	APPROVED	DATE	
© COPYRIGHT HUNTER WATER CORPORATION LIMITED.		APPROVED ASSET STANDARD ENGINEER HUNTER WATER CORPORATION		APPROVED MANAGER ASSET MANAGEMENT HUNTER WATER CORPORATION

HUNTER WATER CORPORATION

A.C.N. 053 102 837



STANDARD DESIGN
RESERVOIR STANDARD

TYPICAL SITE ARRANGEMENT

FILE REFERENCE: HW2009-2368/3/6

HWCS

RES-101

ISSUED: MAY 2011

A3

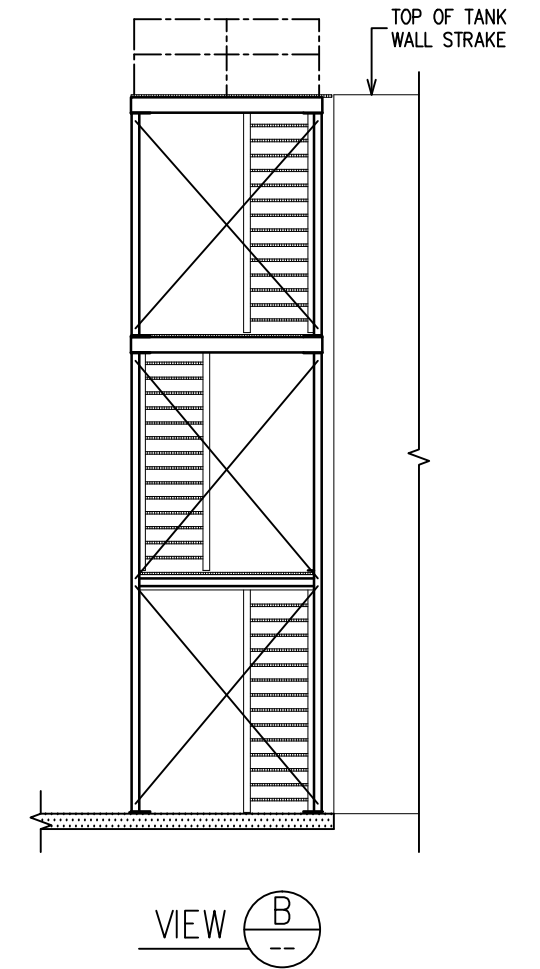
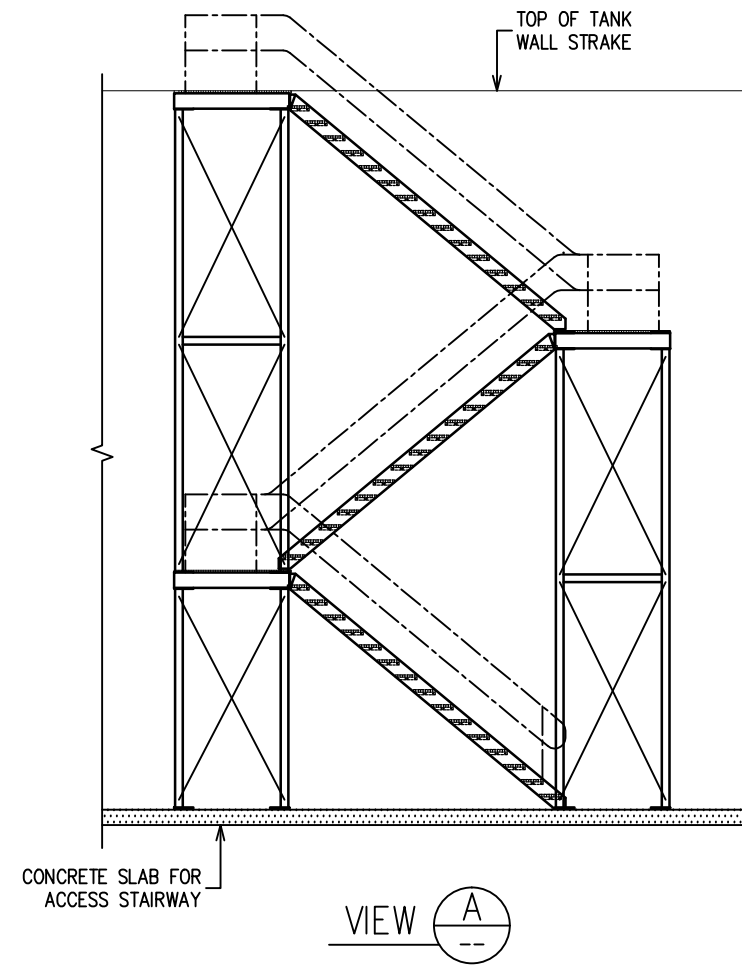
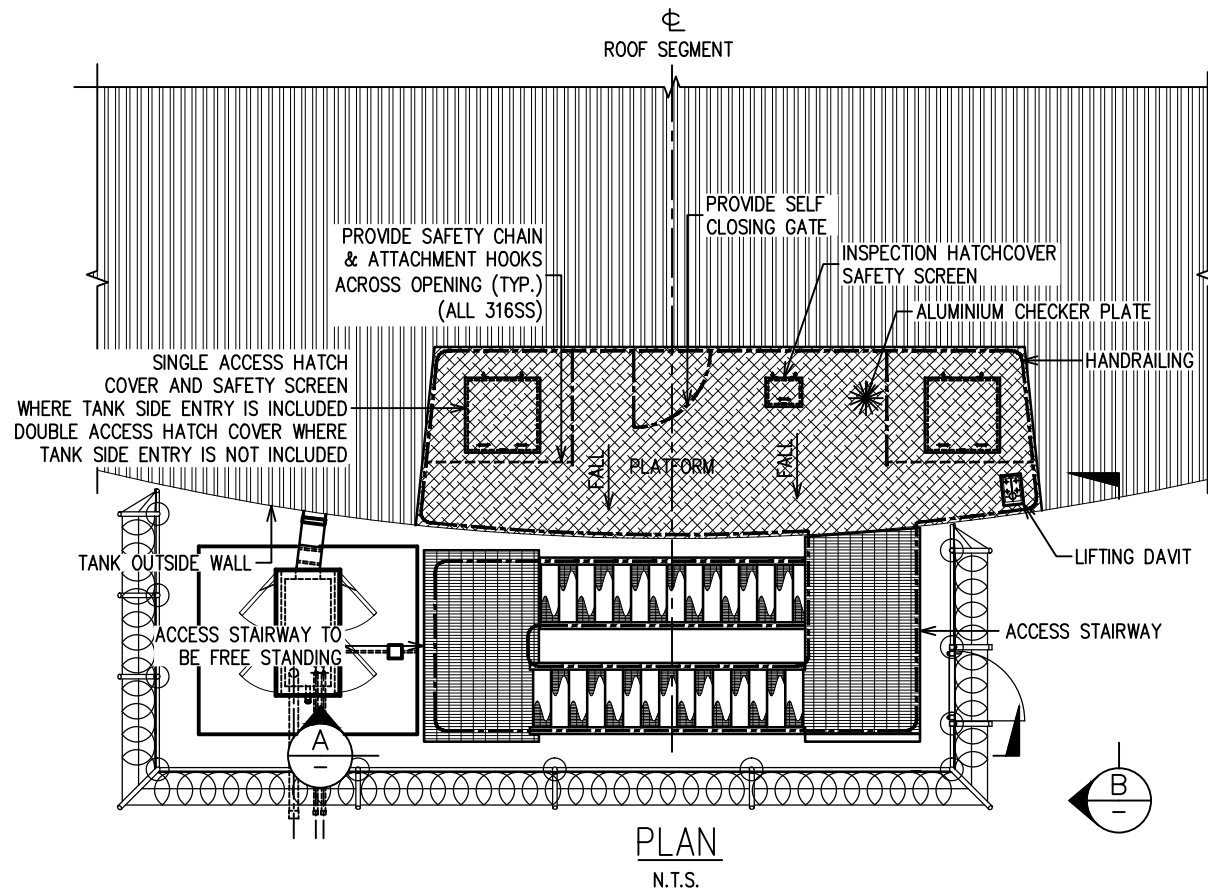

0	ISSUE		S.H	17.05.2011
REV No.	REVISION		APPROVED	DATE
© COPYRIGHT HUNTER WATER CORPORATION LIMITED.		APPROVED ASSET STANDARD ENGINEER HUNTER WATER CORPORATION	APPROVED MANAGER ASSET MANAGEMENT HUNTER WATER CORPORATION	

HUNTER WATER CORPORATION

A.C.N. 053 102 837



STANDARD DESIGN
RESERVOIR STANDARD

TYPICAL ROOF ACCESS REQUIREMENTS

FILE REFERENCE: HW2009-2368/3/6

HWCS

RES-102

ISSUED: MAY 2011

A.3

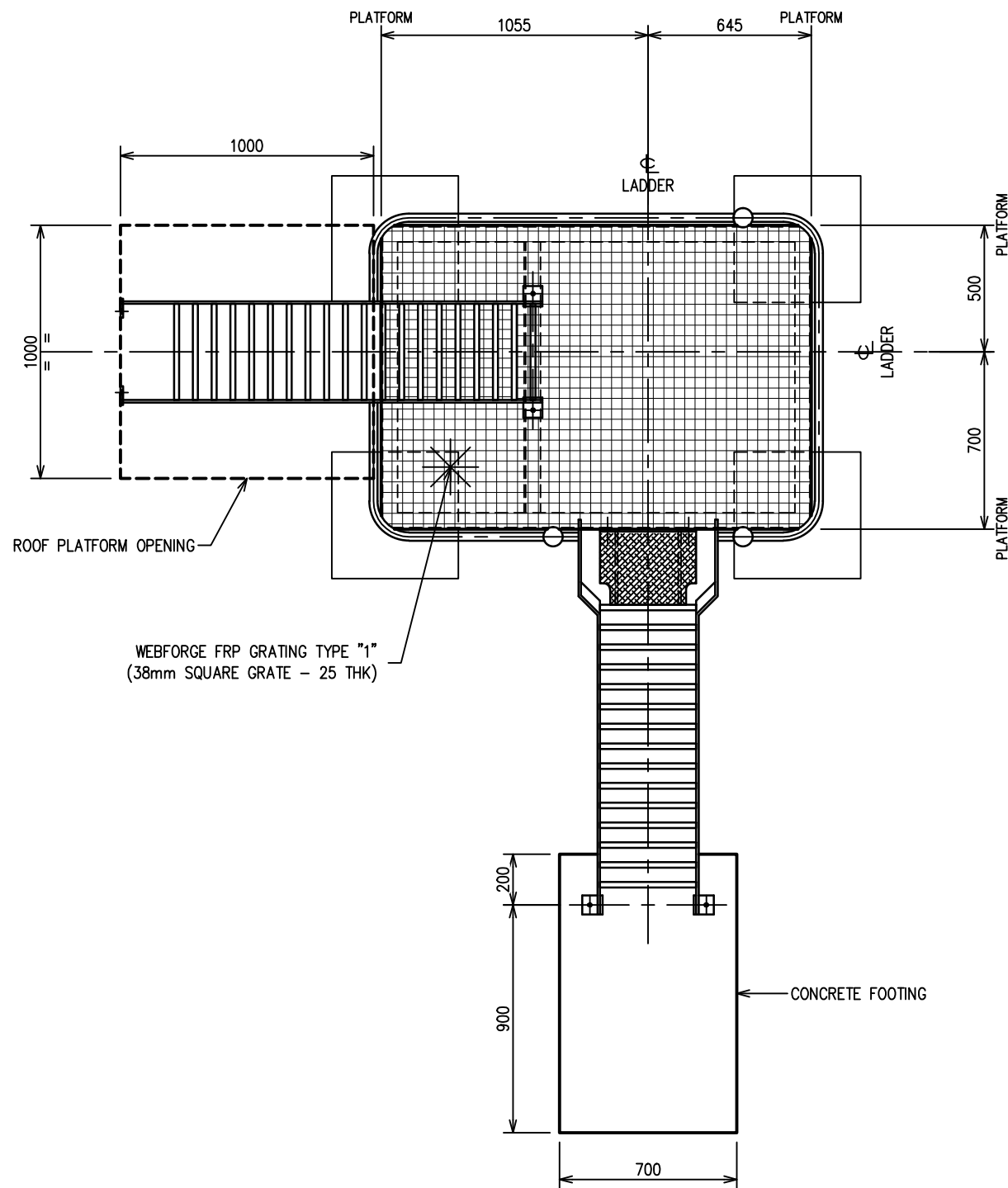

PLAN ON INTERNAL ACCESS LADDER (TYP.)

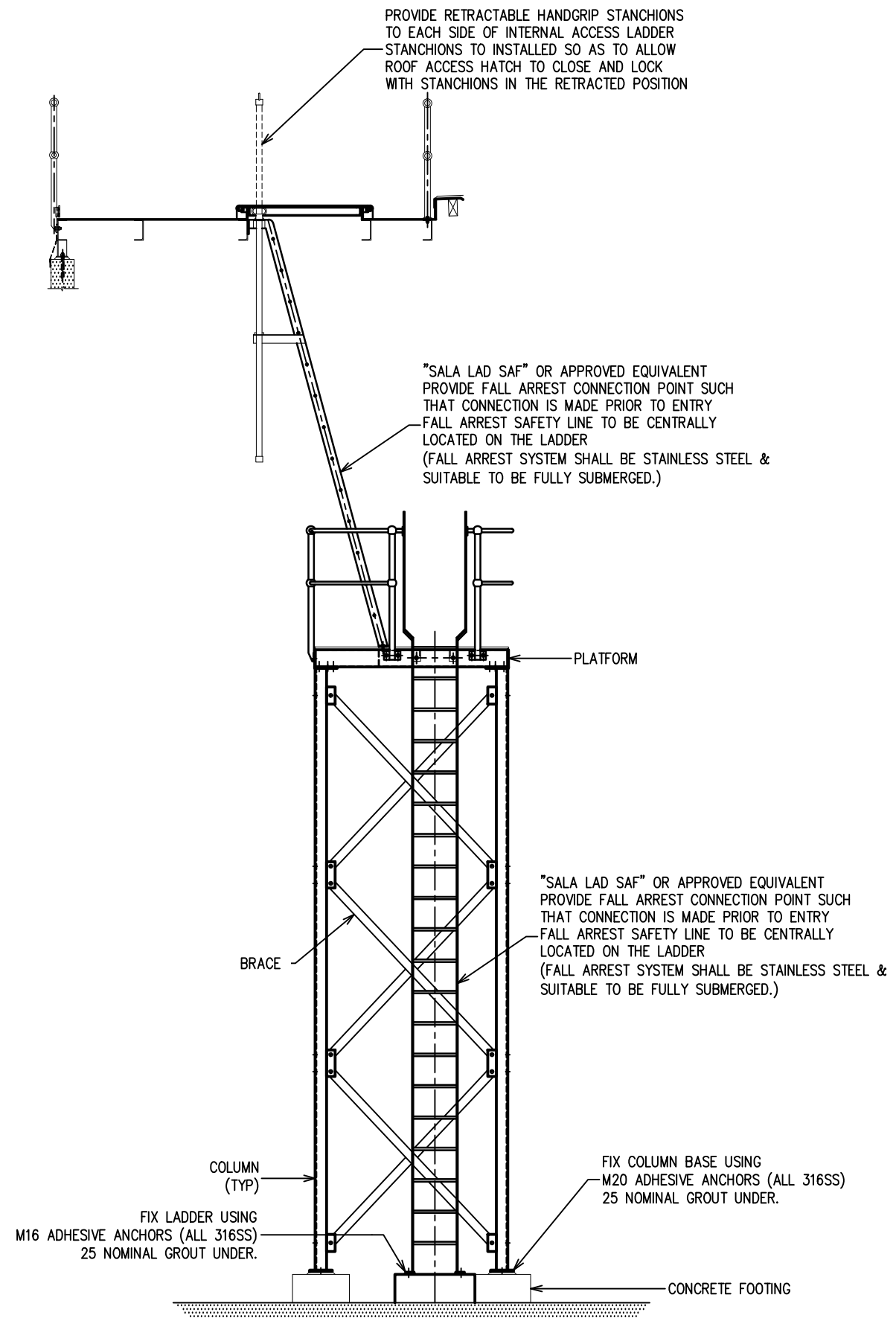

ELEVATION ON INTERNAL ACCESS LADDER (TYP.)

0	ISSUE	S.H	17.05.2011
REV No.	REVISION	APPROVED	DATE
© COPYRIGHT HUNTER WATER CORPORATION LIMITED.		APPROVED ASSET STANDARD ENGINEER HUNTER WATER CORPORATION	
		APPROVED MANAGER ASSET MANAGEMENT HUNTER WATER CORPORATION	

HUNTER WATER CORPORATION

A.C.N. 053 102 837



STANDARD DESIGN
RESERVOIR STANDARD

TYPICAL INTERNAL ACCESS ARRANGEMENT

FILE REFERENCE: HW2009-2368/3/6

HWCS

RES-103

ISSUED: MAY 2011

A.3

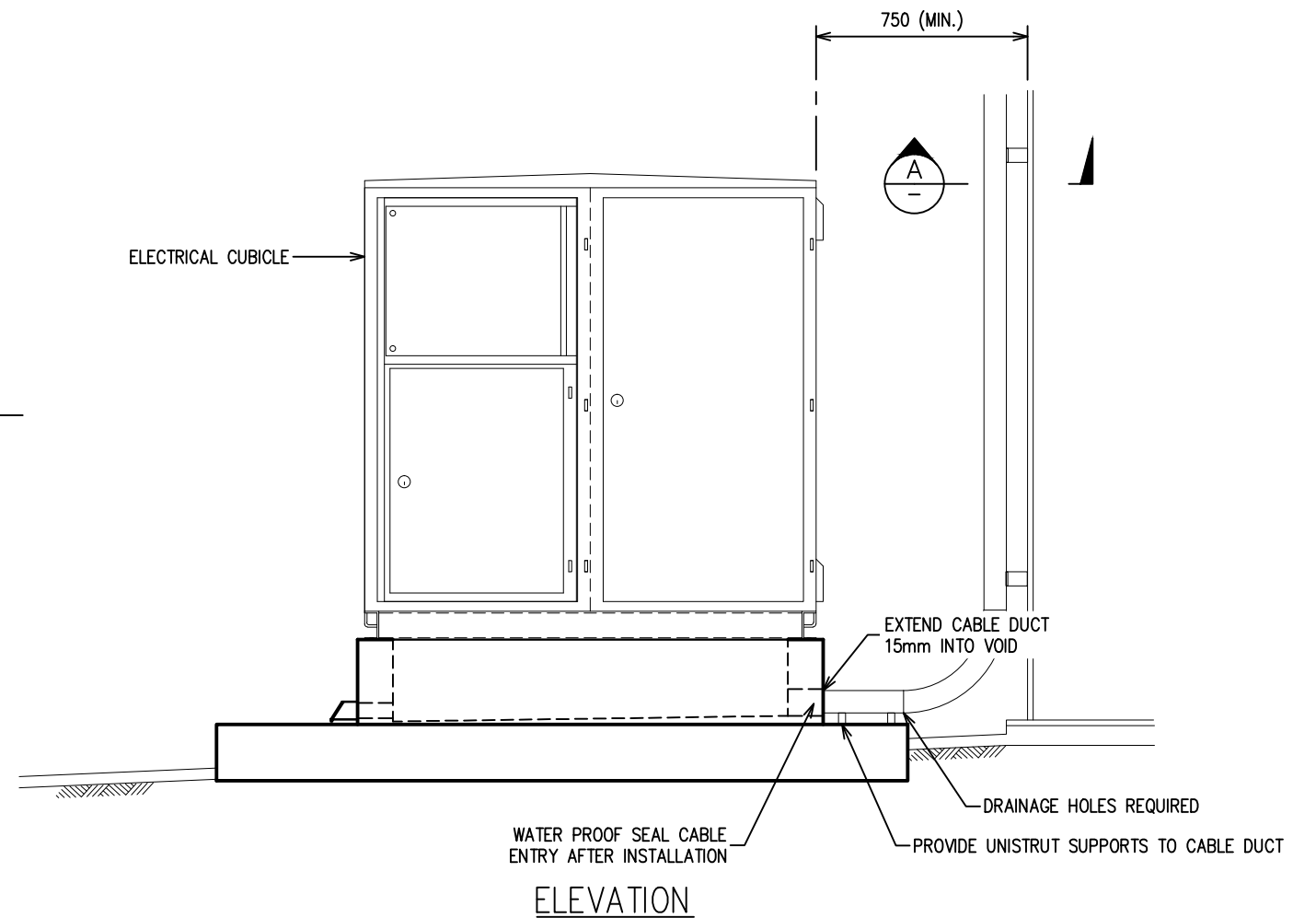
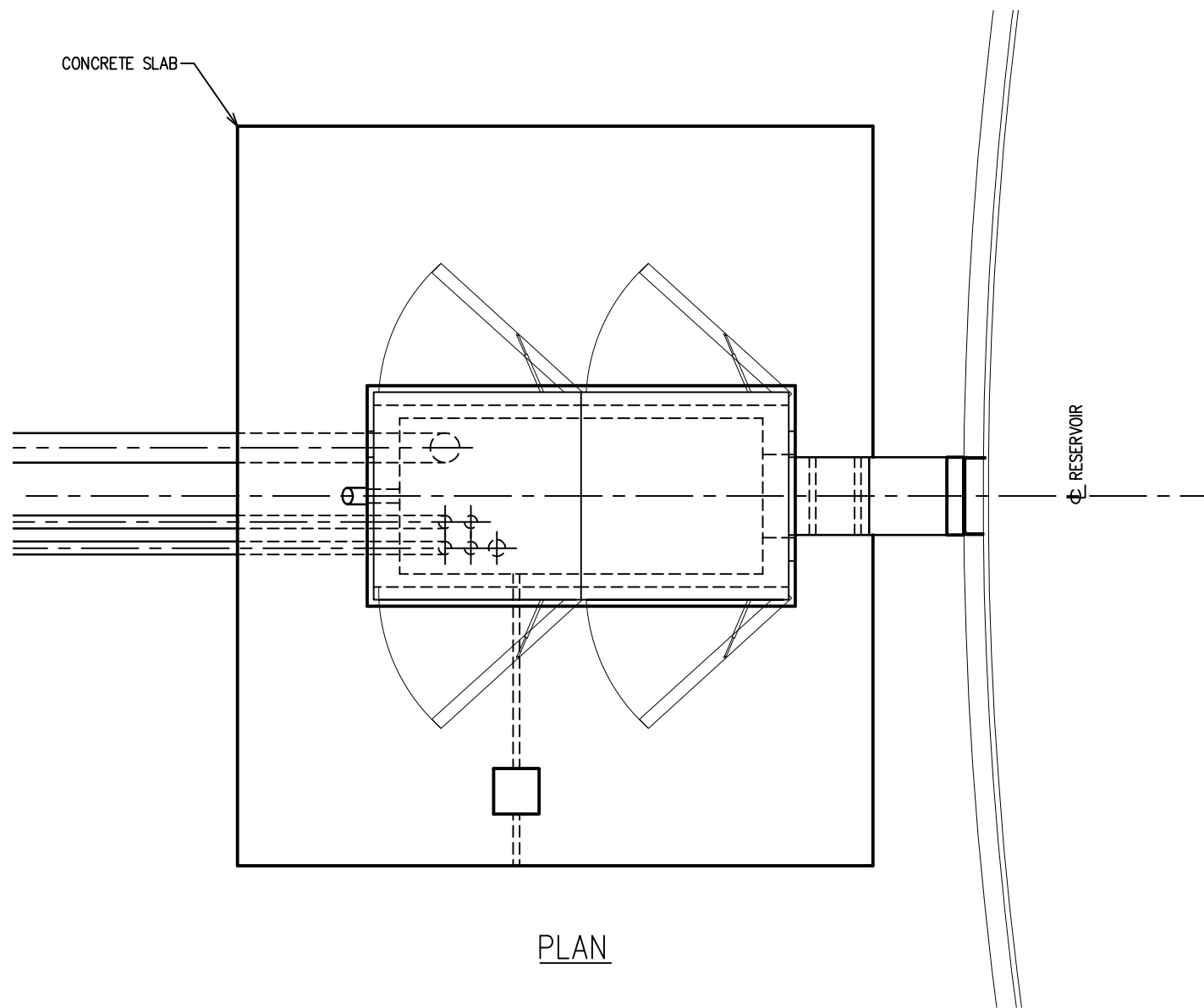
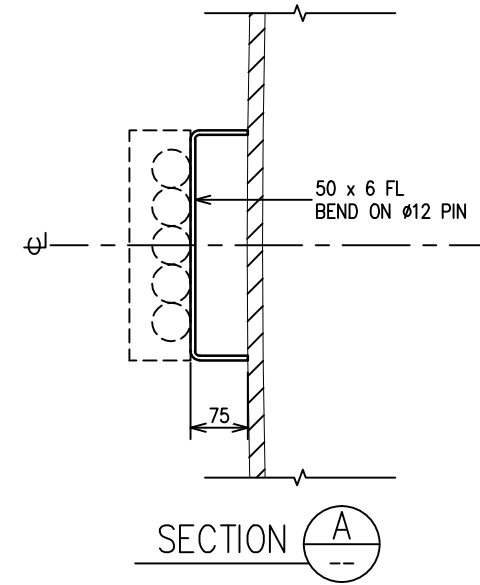

0	ISSUE	S.H	17.05.2011
REV No.	REVISION	APPROVED	DATE
© COPYRIGHT HUNTER WATER CORPORATION LIMITED. APPROVED ASSET STANDARD ENGINEER HUNTER WATER CORPORATION		APPROVED MANAGER ASSET MANAGEMENT HUNTER WATER CORPORATION	

HUNTER WATER CORPORATION
A.C.N. 053 102 837



STANDARD DESIGN
RESERVOIR STANDARD

TYPICAL ELECTRICAL SWITCHBOARD
ARRANGEMENT

FILE REFERENCE: HW2009-2368/3/6

HWCS
RES-104

ISSUED: MAY 2011 | A.3

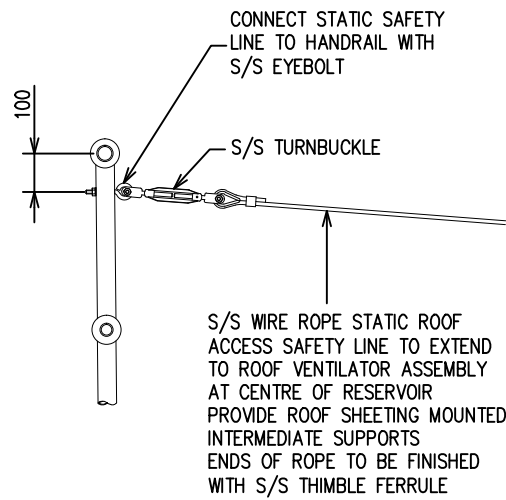

STATIC SAFETY LINE CONNECTION

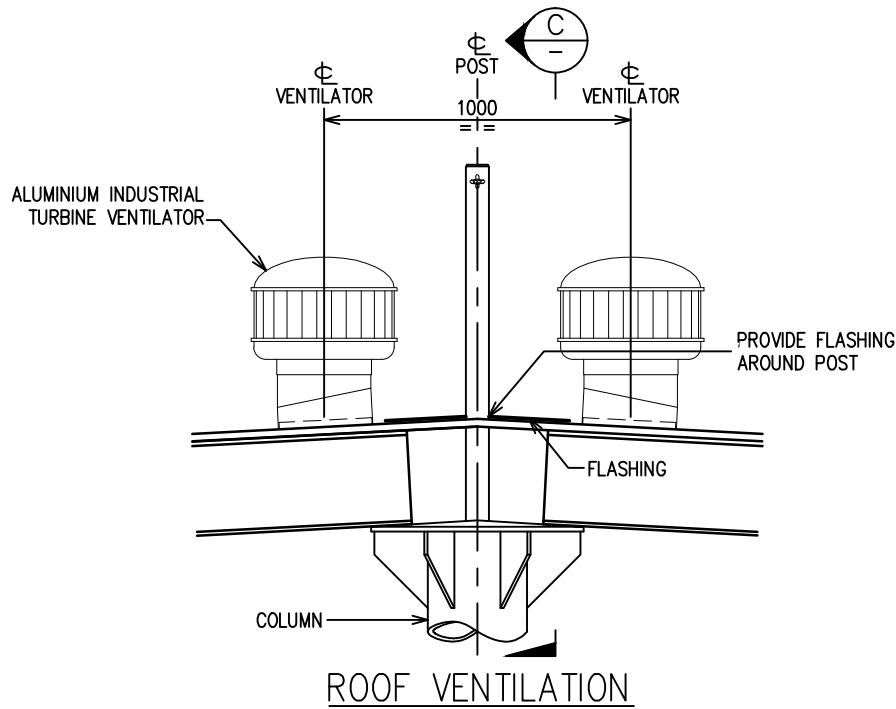

ROOF VENTILATION

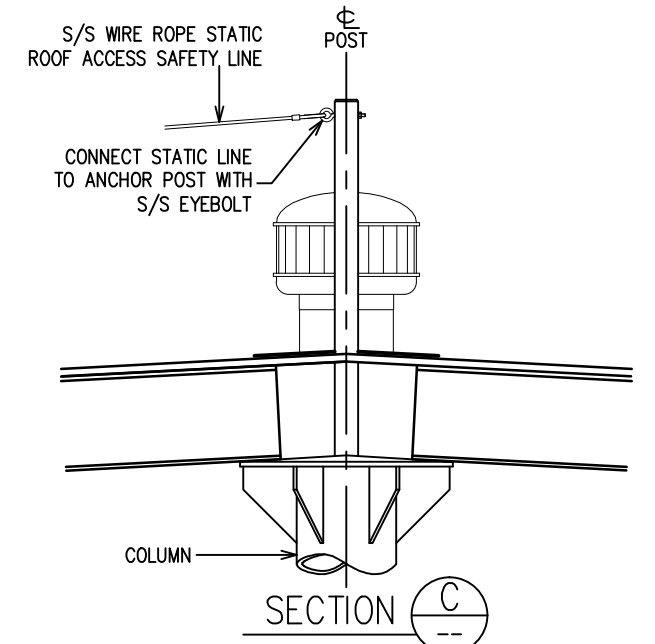

SECTION C

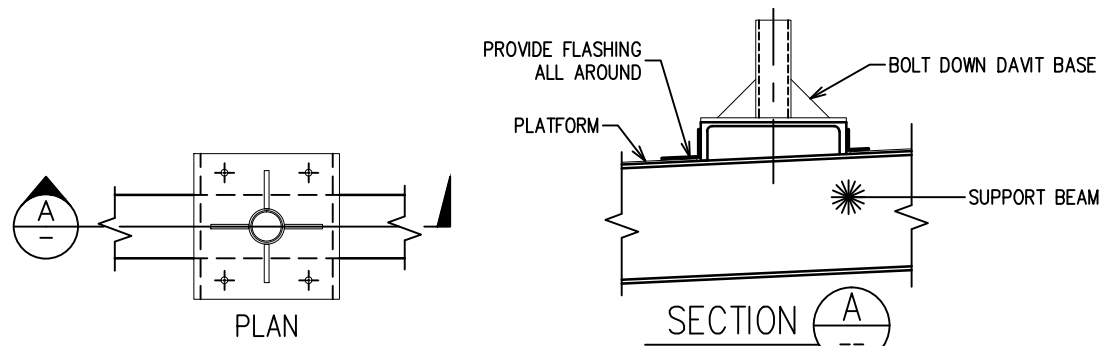

TYPICAL DAVIT INSTALLATION

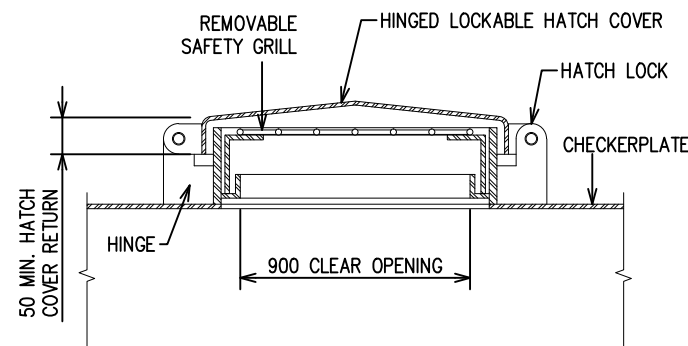

TYPICAL HATCH SECTION

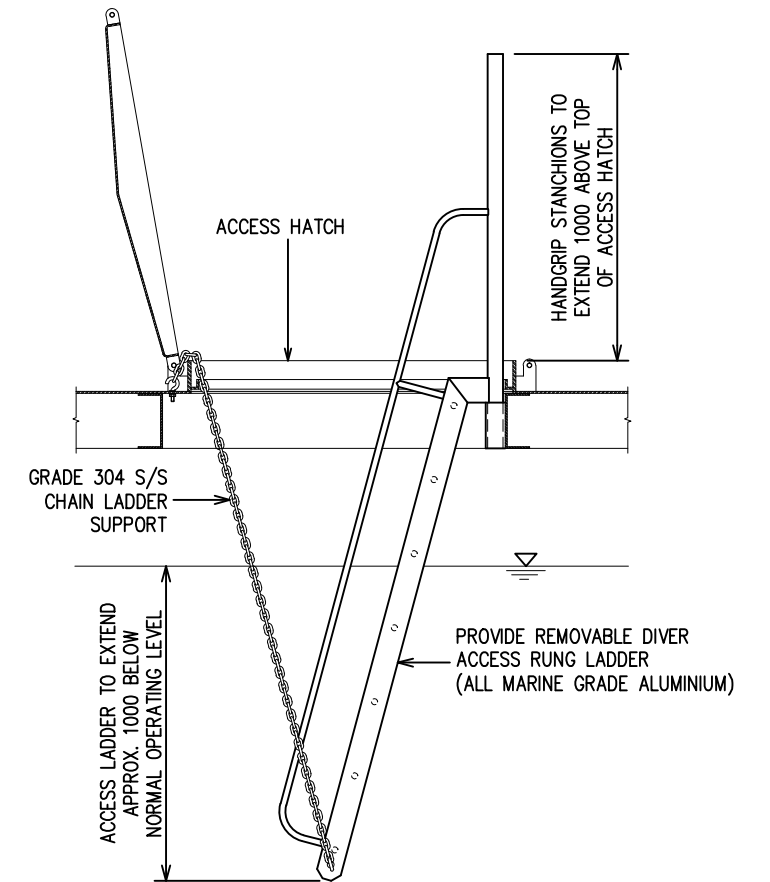

TYPICAL TEMPORARY INTERNAL ACCESS LADDER DETAIL FOR SECOND HATCH (CONCRETE TANKS ONLY)

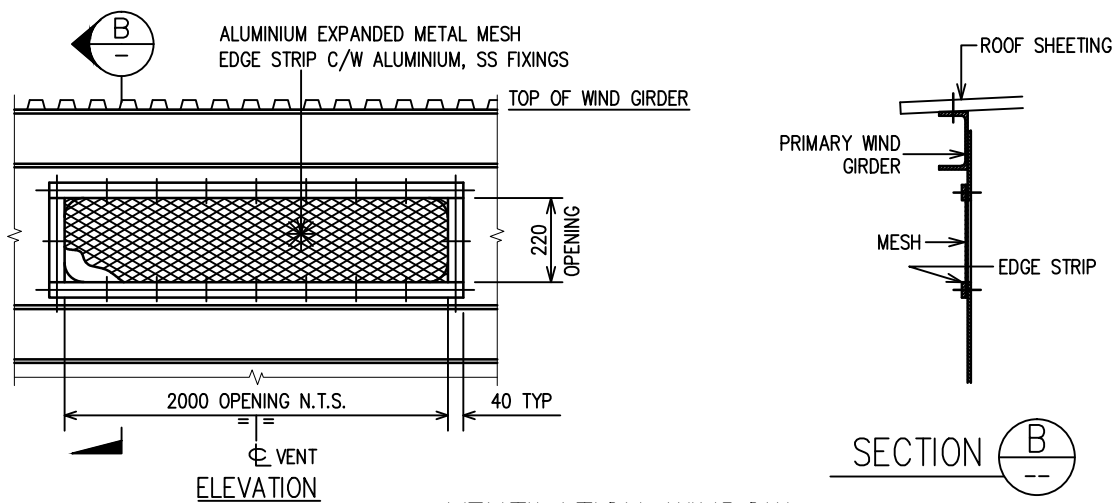

VENTILATION WINDOW MILD STEEL FABRICATED TANKS

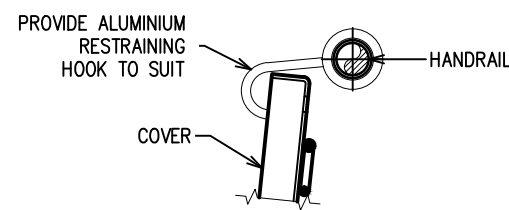

TYPICAL ACCESS COVER RESTRAINING HOOK DETAIL

0	ISSUE		S.H	17.05.2011
REV No.	REVISION		APPROVED	DATE
© COPYRIGHT HUNTER WATER CORPORATION LIMITED.		APPROVED ASSET STANDARD ENGINEER HUNTER WATER CORPORATION	APPROVED MANAGER ASSET MANAGEMENT HUNTER WATER CORPORATION	

HUNTER WATER CORPORATION

A.C.N. 053 102 837



STANDARD DESIGN
RESERVOIR STANDARD

TYPICAL ROOF ACCESS AND VENTILATION DETAILS

FILE REFERENCE: HW2009-2368/3/6

HWCS

RES-105

ISSUED: MAY 2011

A.3

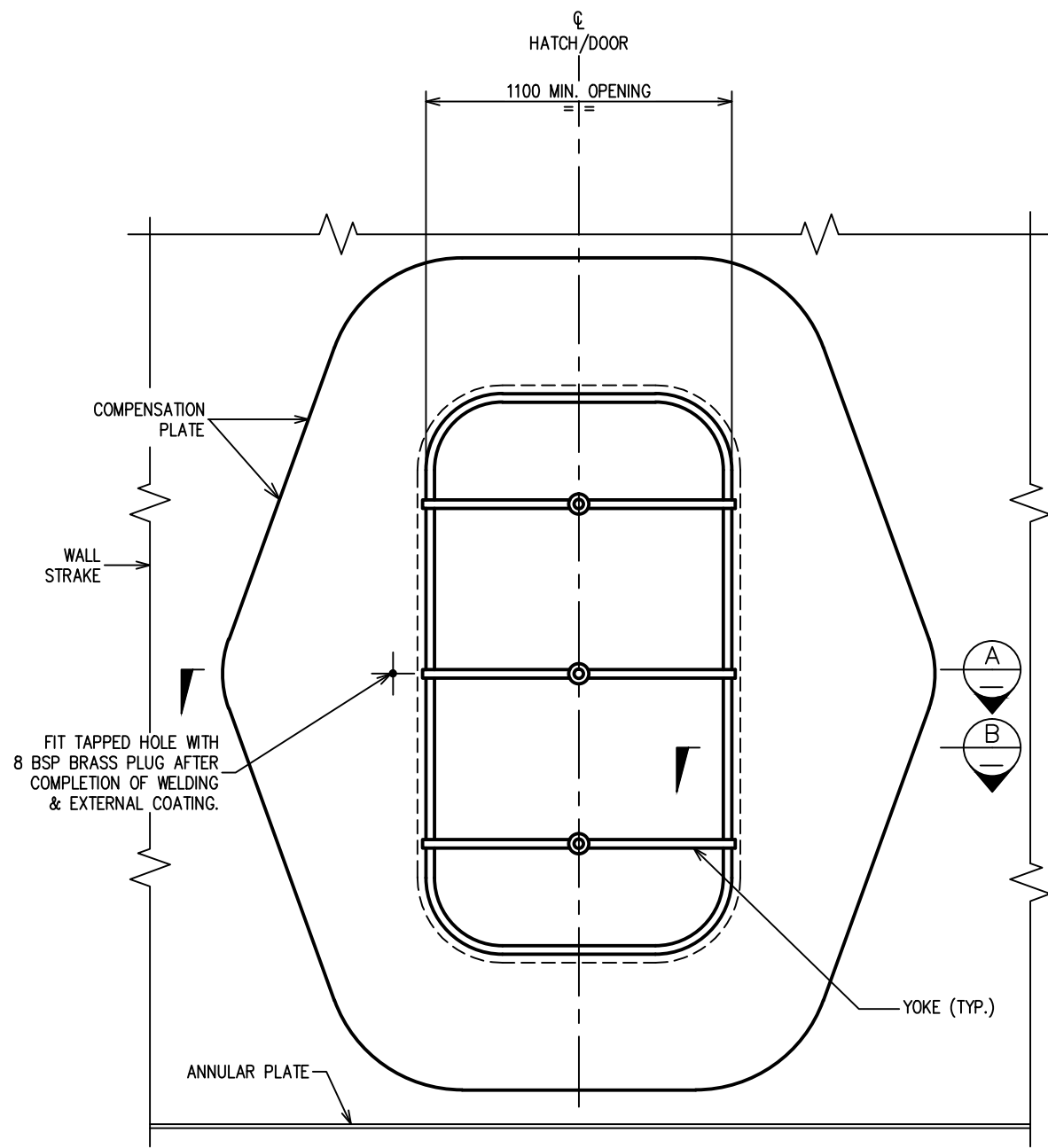

ELEVATION ON EXTERNAL FACE

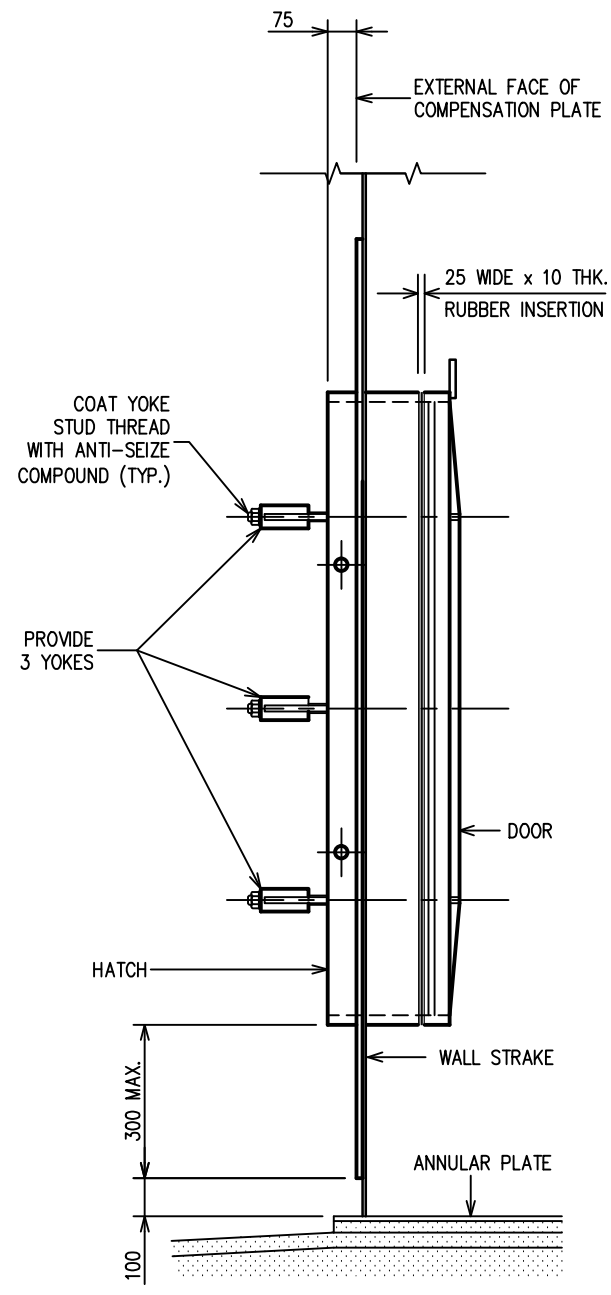

SECTIONAL ELEVATION

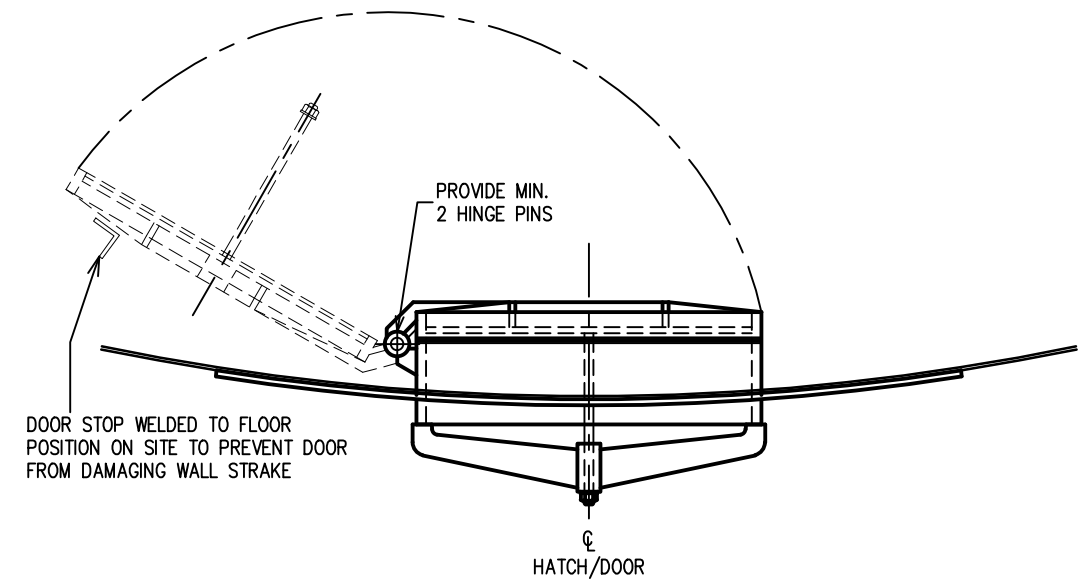

SECTION A

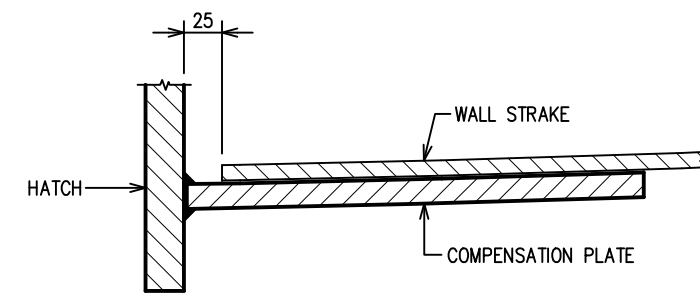

ENLARGED SECTION B

TYPICAL MATERIALS & PERSONNEL ACCESS HATCH
MILD STEEL FABRICATED TANKS

0	ISSUE	S.H	17.05.2011
REV No.	REVISION	APPROVED	DATE
© COPYRIGHT HUNTER WATER CORPORATION LIMITED.		APPROVED ASSET STANDARD ENGINEER HUNTER WATER CORPORATION	
APPROVED MANAGER ASSET MANAGEMENT HUNTER WATER CORPORATION		APPROVED MANAGER ASSET MANAGEMENT HUNTER WATER CORPORATION	

HUNTER WATER CORPORATION

A.C.N. 053 102 837



STANDARD DESIGN
RESERVOIR STANDARD

TYPICAL PERSONNEL ACCESS
HATCH REQUIREMENTS

FILE REFERENCE: HW2009-2368/3/6

HWCS

RES-106

ISSUED: MAY 2011

A.3

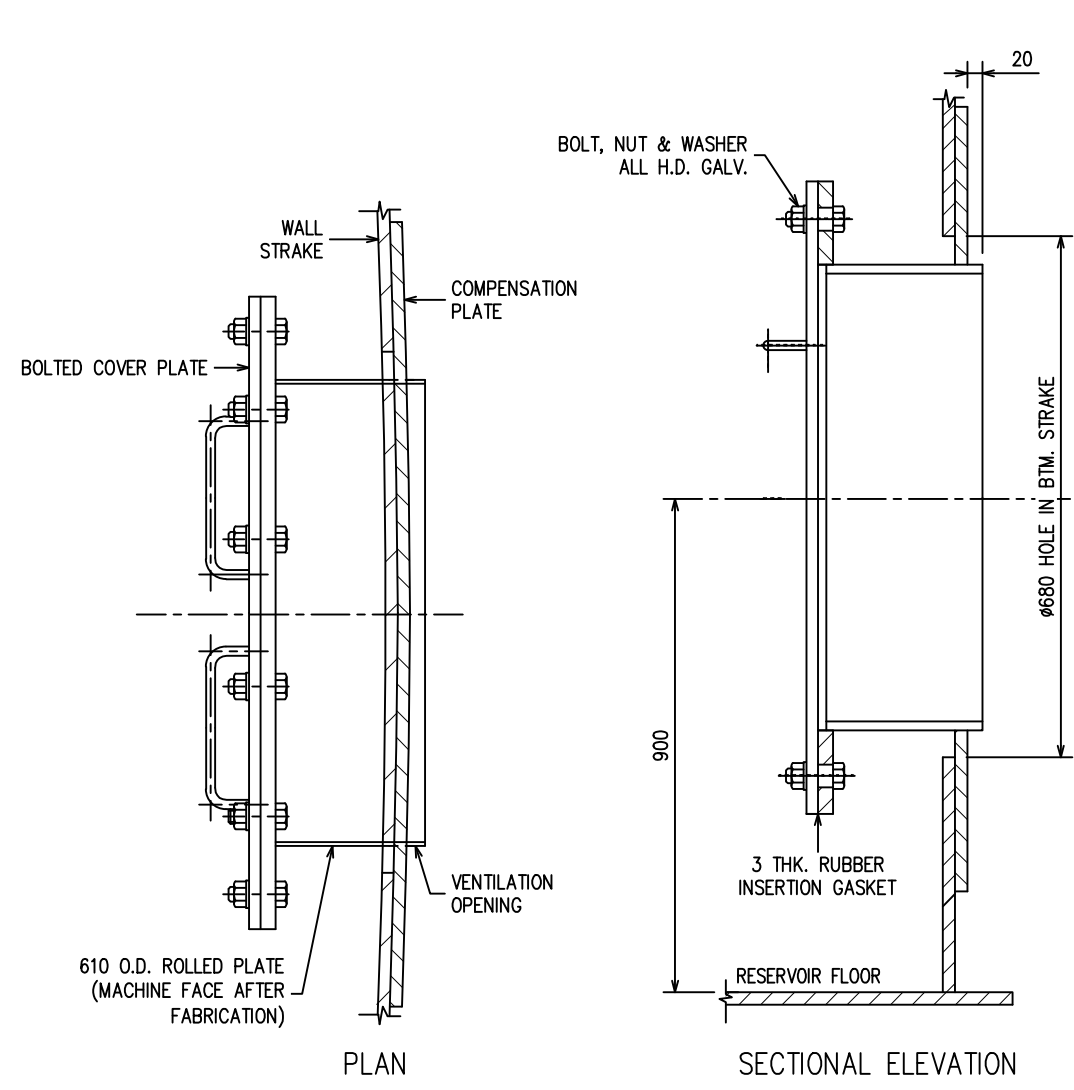

TYPICAL ARRANGEMENT

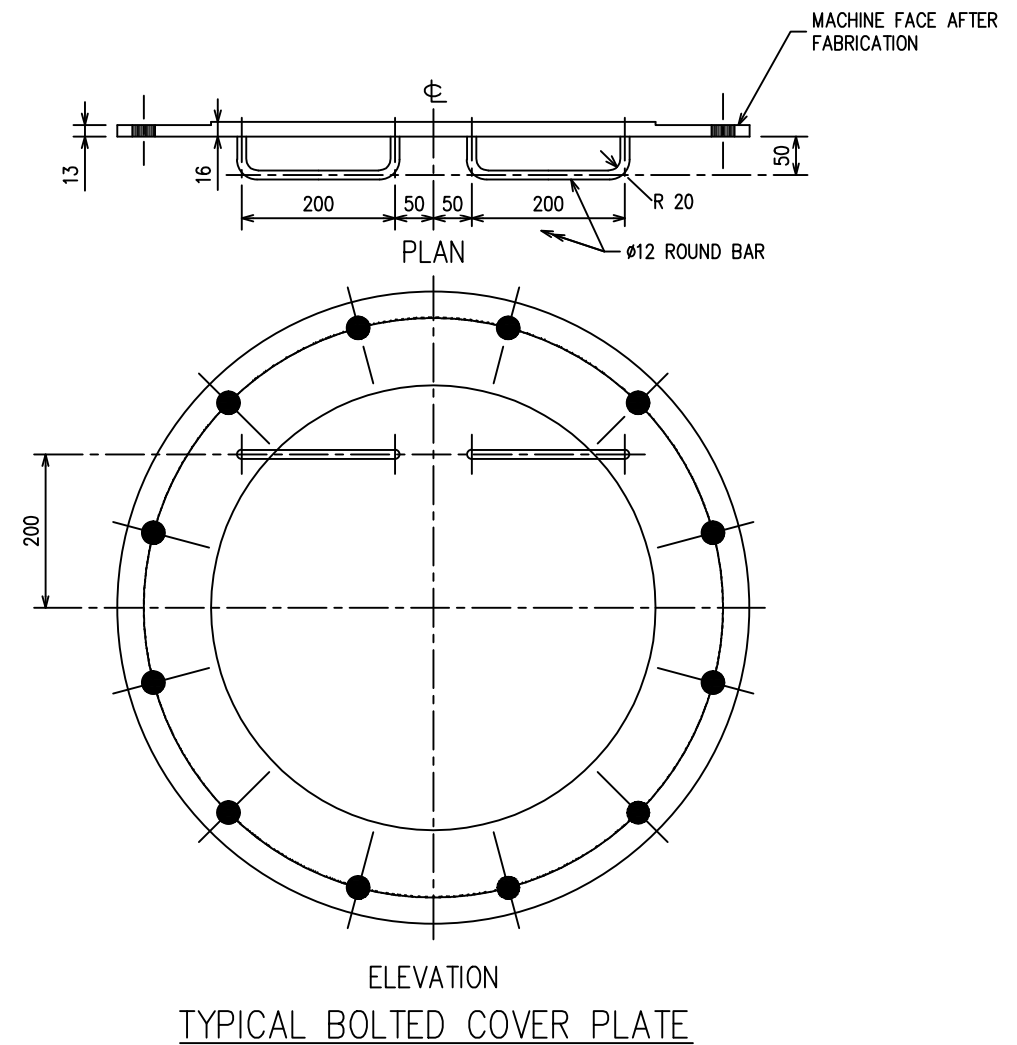

ELEVATION
TYPICAL BOLTED COVER PLATE

ACCESS VENTILATION OPENING
MILD STEEL FABRICATED TANK

0	ISSUE	S.H	17.05.2011
REV No.	REVISION	APPROVED	DATE
© COPYRIGHT HUNTER WATER CORPORATION LIMITED. APPROVED ASSET STANDARD ENGINEER HUNTER WATER CORPORATION		APPROVED MANAGER ASSET MANAGEMENT HUNTER WATER CORPORATION	

HUNTER WATER CORPORATION
A.C.N. 053 102 837

STANDARD DESIGN
RESERVOIR STANDARD

TYPICAL ACCESS VENTILATION
OPENING REQUIREMENTS

FILE REFERENCE: HW2009-2368/3/6

HWCS
RES-107

ISSUED: MAY 2011 | A.3

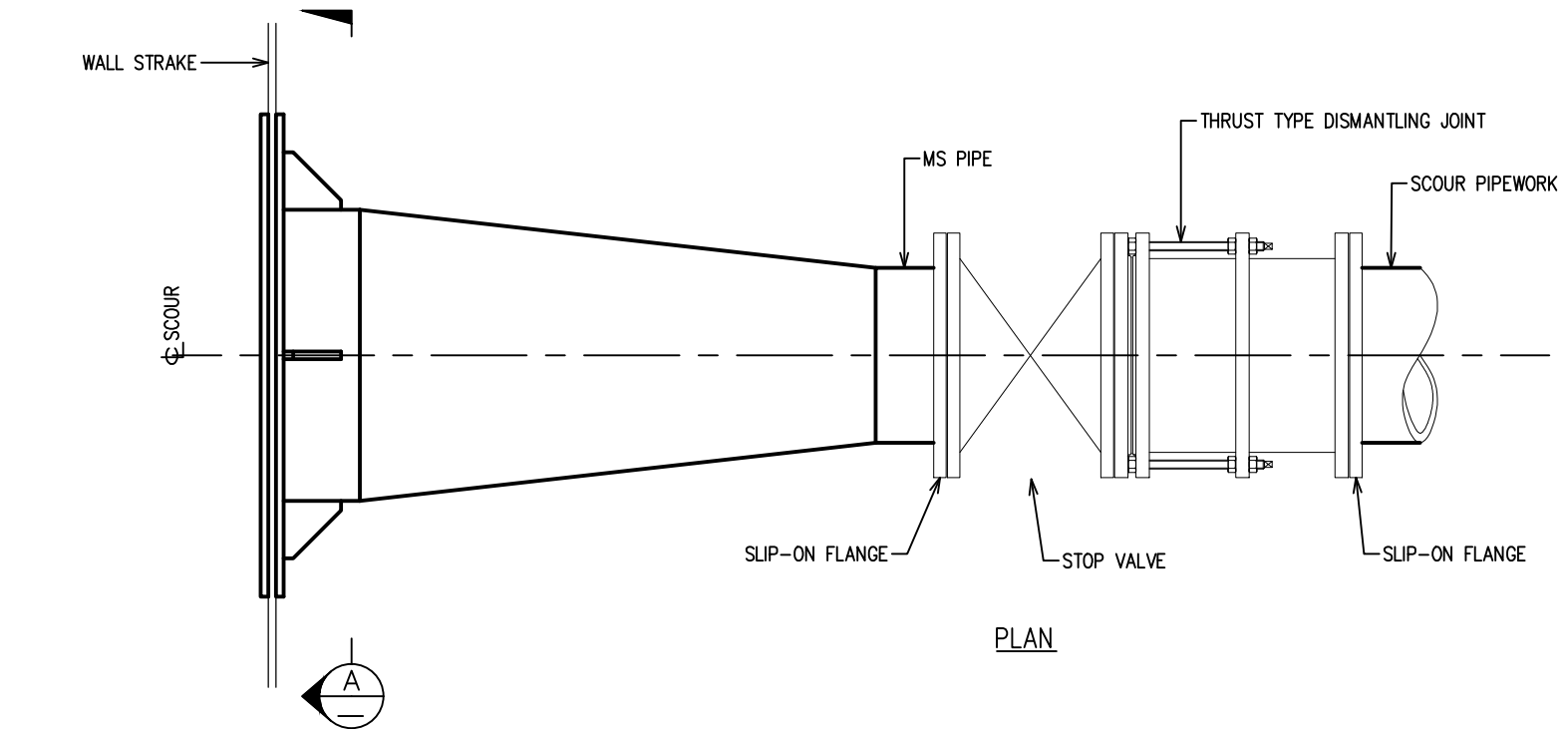

PLAN

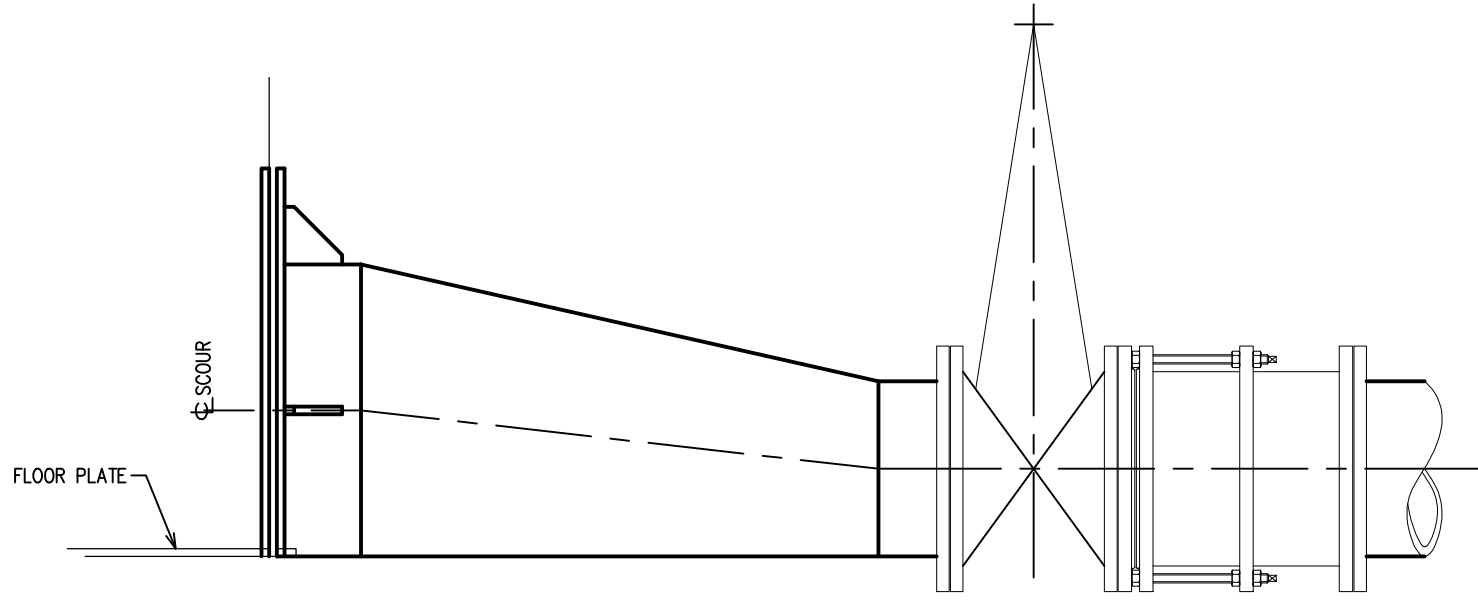

ELEVATION

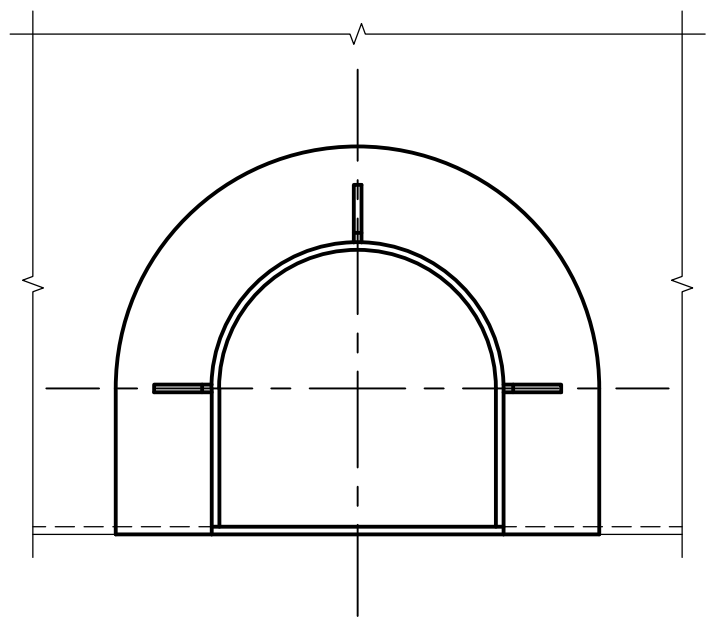

SECTION A

TYPICAL ARRANGEMENT
MILD STEEL FABRICATED TANK

0	ISSUE	S.H	17.05.2011
REV No.	REVISION	APPROVED	DATE
© COPYRIGHT HUNTER WATER CORPORATION LIMITED. APPROVED ASSET STANDARD ENGINEER HUNTER WATER CORPORATION		APPROVED MANAGER ASSET MANAGEMENT HUNTER WATER CORPORATION	

HUNTER WATER CORPORATION
A.C.N. 053 102 837



STANDARD DESIGN
RESERVOIR STANDARD

TYPICAL RESERVOIR SCOUR & WASHOUT

FILE REFERENCE: HW2009-2368/3/6

HWCS
RES-108

ISSUED: MAY 2011 | A3

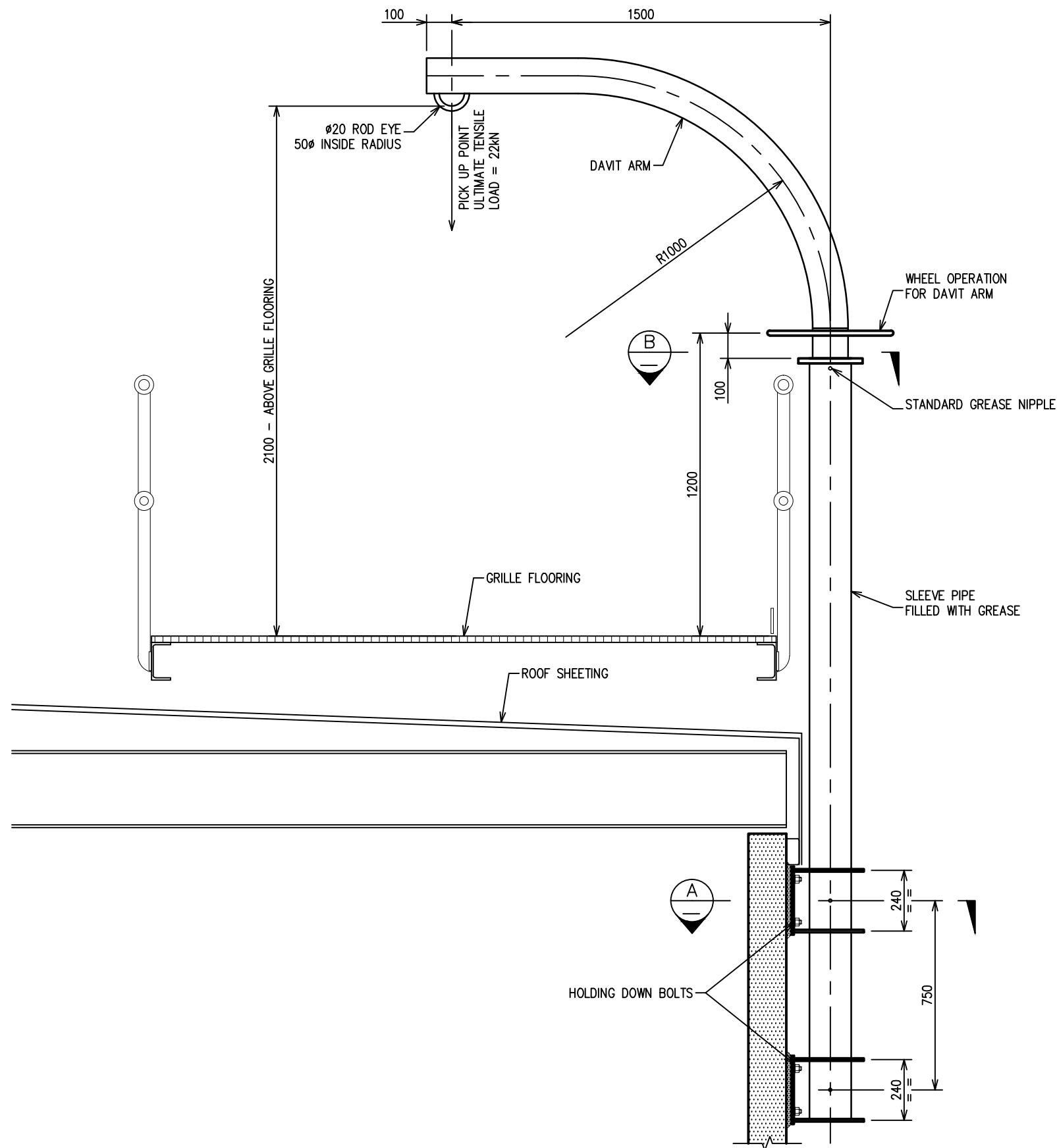

DAVIT SUPPORT ARM ELEVATION

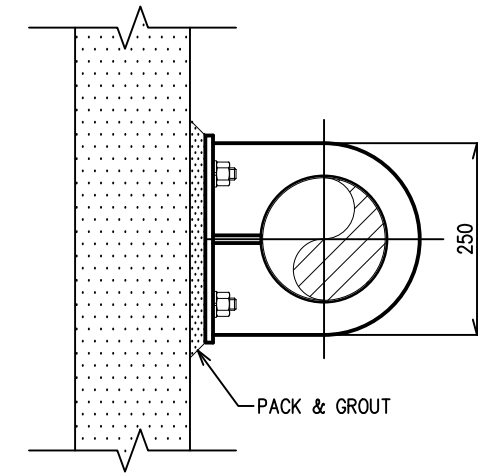

SECTION A
SCALE 1:10

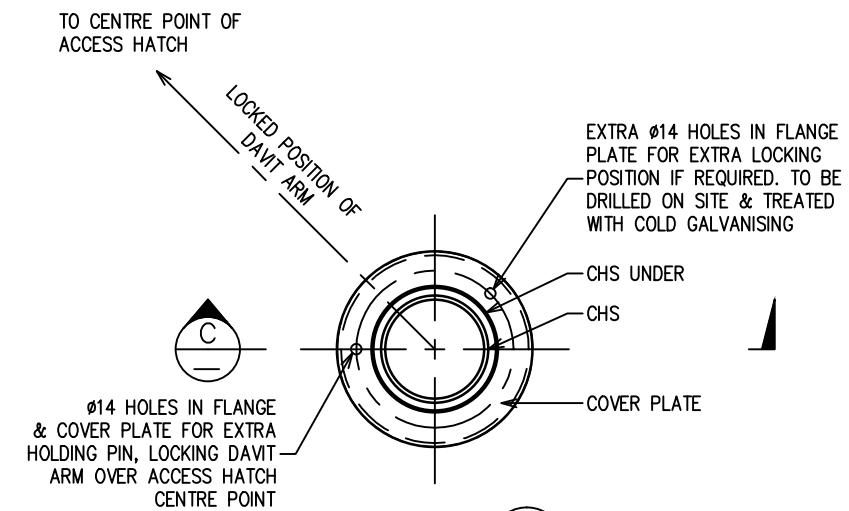

SECTION B
SCALE 1:10

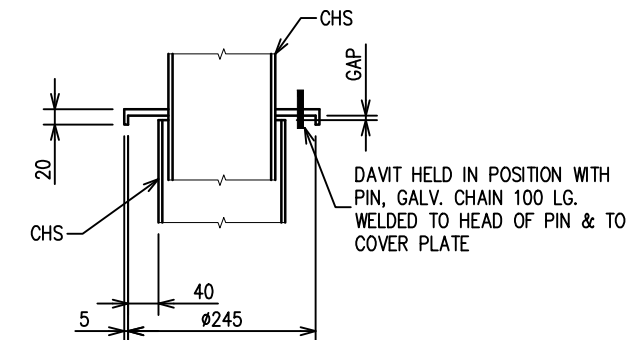

SECTION C
SCALE 1:10

0	ISSUE		S.H	17.05.2011
REV No.	REVISION		APPROVED	DATE
© COPYRIGHT HUNTER WATER CORPORATION LIMITED.		APPROVED ASSET STANDARD ENGINEER HUNTER WATER CORPORATION	APPROVED MANAGER ASSET MANAGEMENT HUNTER WATER CORPORATION	

HUNTER WATER CORPORATION

A.C.N. 053 102 837



STANDARD DESIGN
RESERVOIR STANDARD

TYPICAL DAVIT ARM DETAILS

FILE REFERENCE: HW2009-2368/3/6

HWCS

RES-109

ISSUED: MAY 2011

A3

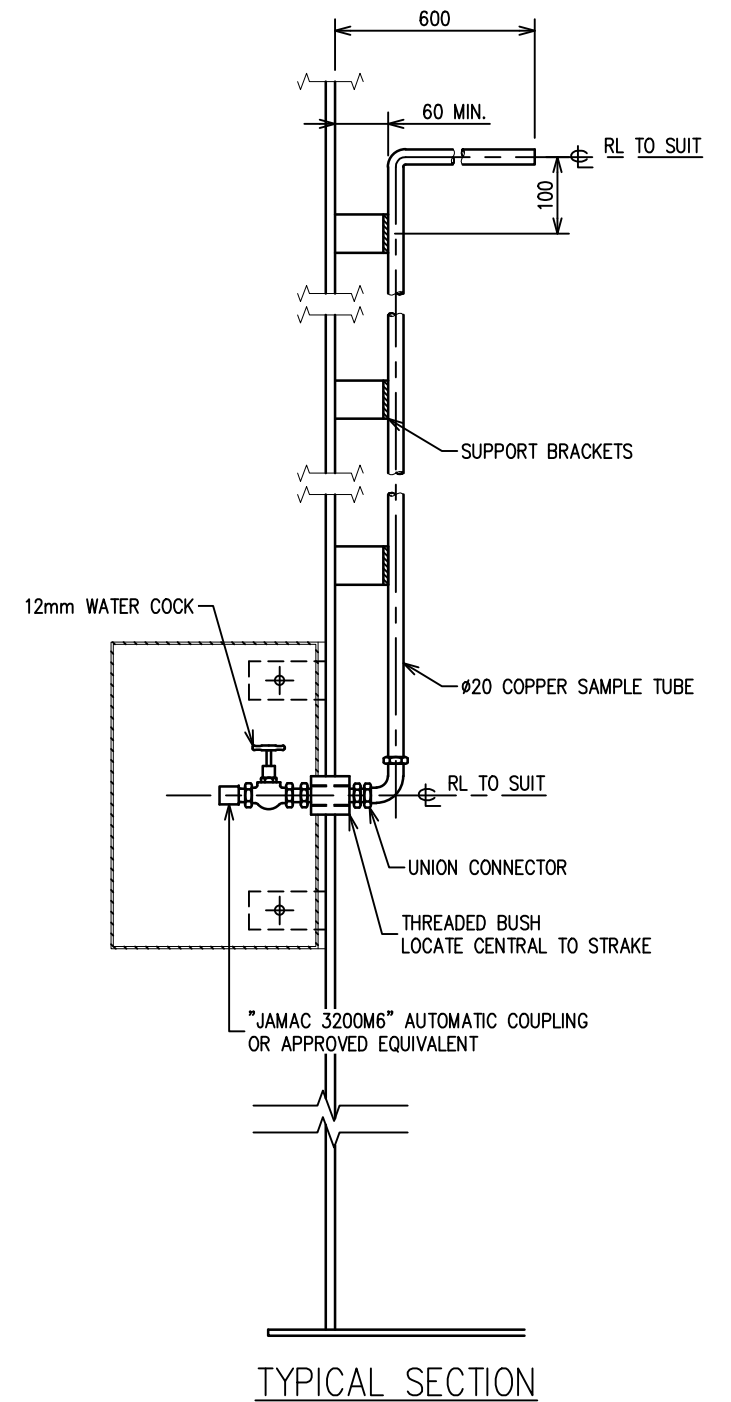
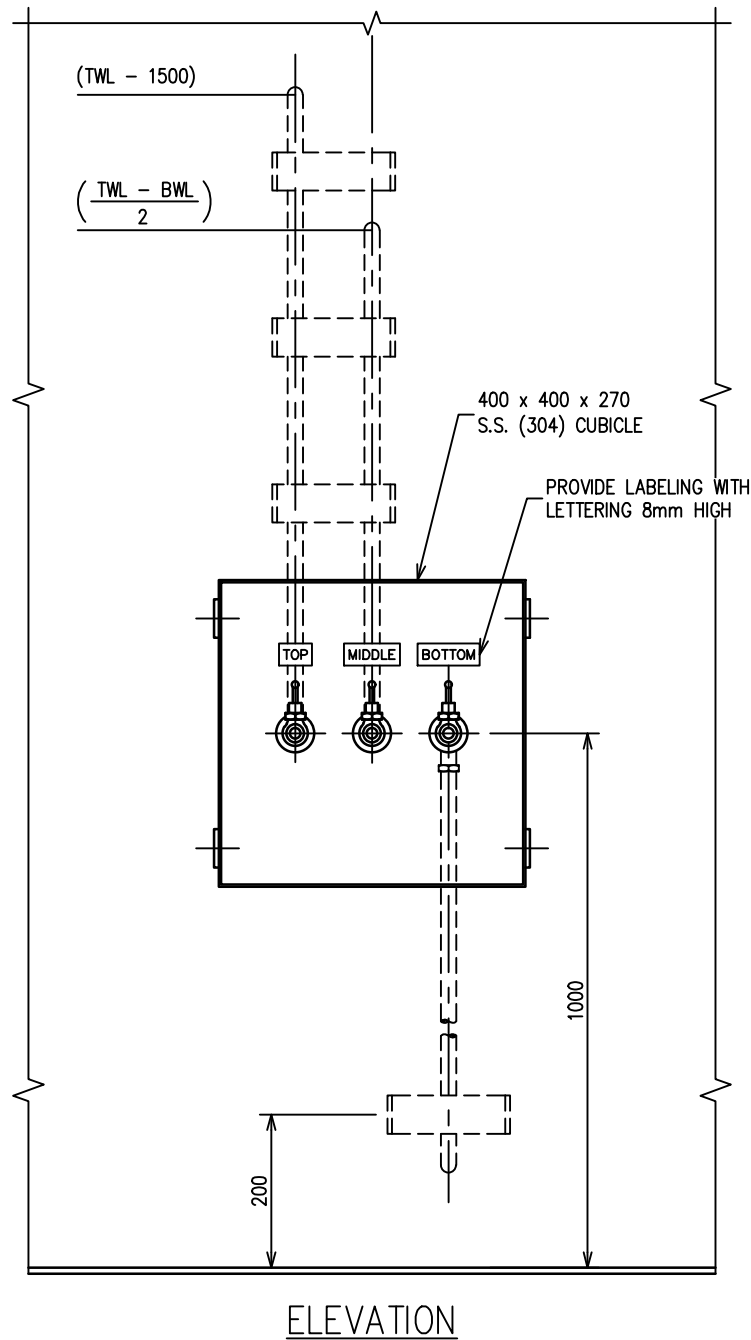
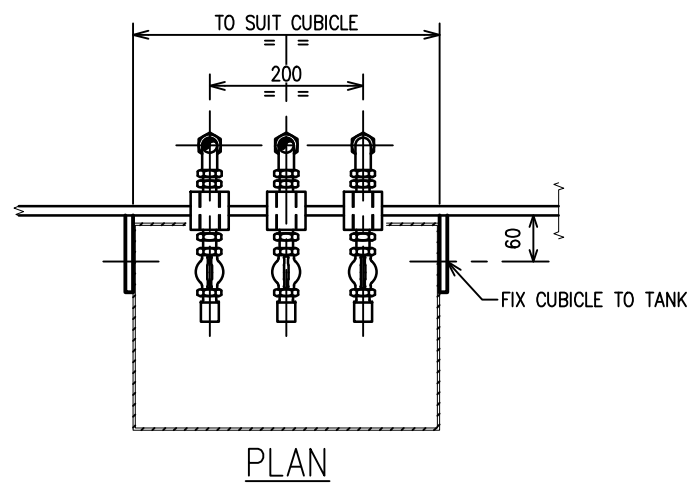

0	ISSUE	S.H	17.05.2011
REV No.	REVISION	APPROVED	DATE
© COPYRIGHT HUNTER WATER CORPORATION LIMITED.		APPROVED ASSET STANDARD ENGINEER HUNTER WATER CORPORATION	
APPROVED MANAGER ASSET MANAGEMENT HUNTER WATER CORPORATION		APPROVED MANAGER ASSET MANAGEMENT HUNTER WATER CORPORATION	

HUNTER WATER CORPORATION

A.C.N. 053 102 837



STANDARD DESIGN
RESERVOIR STANDARD

TYPICAL SAMPLING POINT REQUIREMENTS

FILE REFERENCE: HW2009-2368/3/6

HWCS

RES-110

ISSUED: MAY 2011

A3

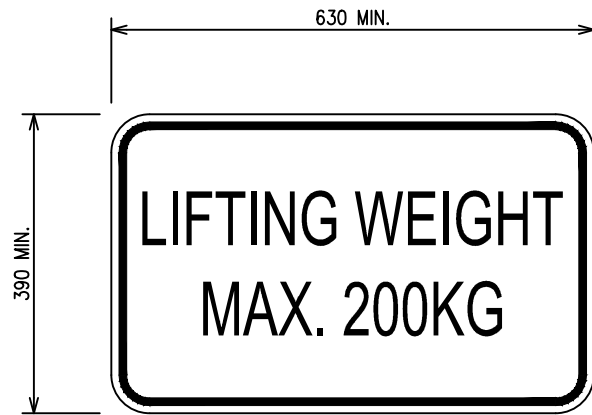

LIFTING WEIGHT SIGN
N.T.S.

- LIFTING WEIGHT SIGNS SHALL BE INSTALLED AS FOLLOWS:
- ONE SIGN ON DIVERS WORKING PLATFORM NEXT TO DERRICK BASE.
 - ONE SIGN 2m ABOVE FINISHED GROUND SURFACE AND DIRECTLY UNDER DERRICK ARM BELOW DIVERS WORKING PLATFORM

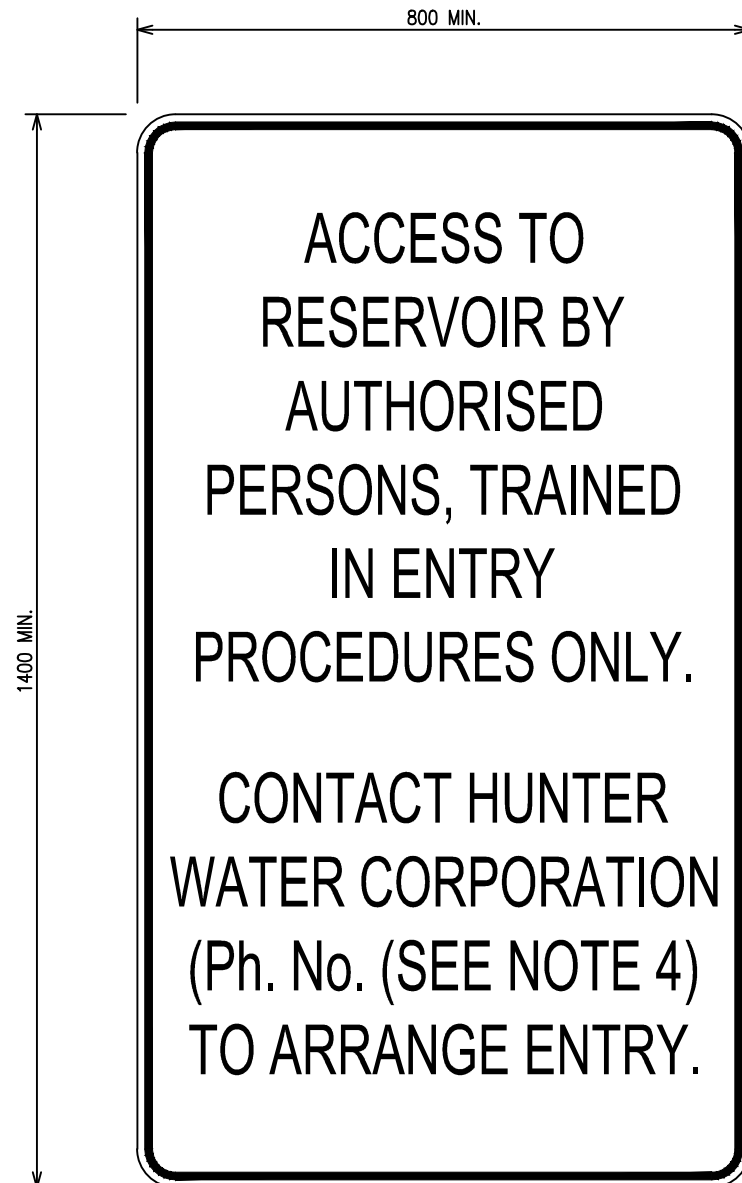

ACCESS SIGN
N.T.S.

SIGN TO BE FIXED TO THE RESERVOIR GUARD DOOR



ACCESS SIGN
N.T.S.

SIGN TO BE ON THE DRIVERS WORKING PLATFORM

NOTE: THIS IS AN EXAMPLE ONLY, ACTUAL DESIGN AND CONSTRUCTION DRAWING SHALL SUIT PROJECT REQUIREMENT.

NOTES:

1. ALL SIGNS SHALL BE IN ACCORDANCE WITH AS 1319.
2. SIGNS SHALL BE IN HELVETICA MEDIUM BLACK LETTERS.
3. YELLOW BACKGROUND COLOUR SHALL BE FOR LIFTING WEIGHT SIGN, WHITE COLOUR FOR ACCESS SIGNS.
4. PHONE NUMBER SHALL BE ADVISED BY THE SUPERINTENDENT.
5. MATERIAL FOR SIGNS SHALL BE METAL MATERIAL SUCH AS COLORBOND STEEL OR EQUIV.

0	ISSUE	S.H	17.05.2011
REV No.	REVISION	APPROVED	DATE
© COPYRIGHT HUNTER WATER CORPORATION LIMITED.		APPROVED ASSET STANDARD ENGINEER HUNTER WATER CORPORATION	
		APPROVED MANAGER ASSET MANAGEMENT HUNTER WATER CORPORATION	

HUNTER WATER CORPORATION
A.C.N. 053 102 837



STANDARD DESIGN
RESERVOIR STANDARD

TYPICAL RESERVOIR SIGNAGE

FILE REFERENCE: HW2009-2368/3/6

HWCS
RES-111

ISSUED: MAY 2011 | A.3

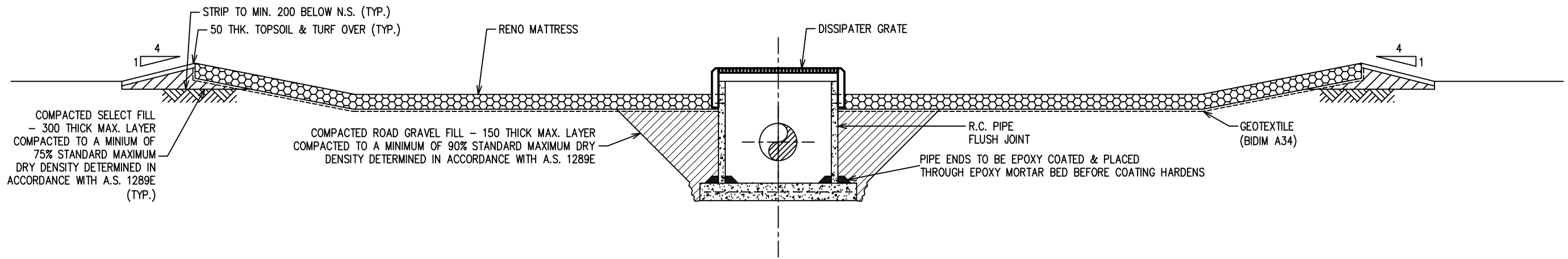

TYPICAL SECTION
PERPENDICULAR TO PIPEWORK
SCALE 1:50

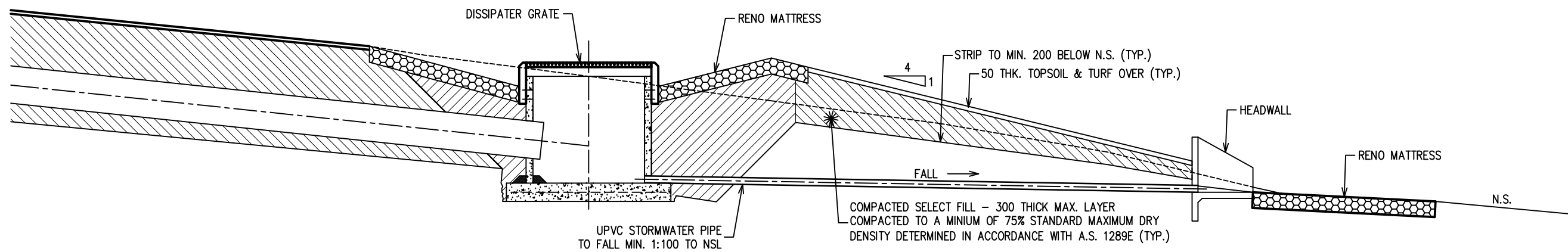

TYPICAL SECTION
PARALLEL TO PIPEWORK
SCALE 1:50

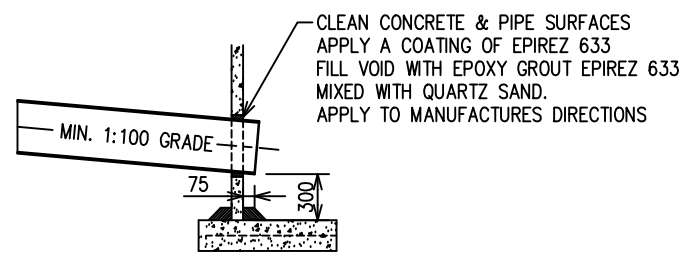

TYPICAL PIPE PENETRATION OF PIT
SCALE 1:50

NOTE:

- RENO MATTRESS TO COMPRISE 230 THK MATTRESS MANUFACTURED FROM PVC SLEEVED HEAVY GALVANISED WIRE.
 - MESH SIZE 60mm x 80mm.
 - CORE WIRE ϕ 2mm
 - SELVEDGE WIRE ϕ 2.7mm
- MATTRESS TO BE UNDER-LAID WITH NON-WOVEN GEOTEXTILE (BIDMA A34 OR EQUIVALENT). FILL MATERIAL TO BE HARD DURABLE IGNEOUS STONE OF NOT LESS THAN 2000kg/m³ BULK DENSITY.
- MATTRESS TO BE PEGGED IN POSITION WITH 90° 'L' BARS BENT FROM N16 REINFORCEMENT BAR (LONG LEG-500mm/SHORT LEG-150mm, HOT DIP GALVANISED FINISH POST BENDING). PEGS TO BE LOCATED AT NOM 2.0m PITCH BOTH DIRECTIONS.

0	ISSUE	S.H	17.05.2011
REV No.	REVISION	APPROVED	DATE
© COPYRIGHT HUNTER WATER CORPORATION LIMITED. APPROVED ASSET STANDARD ENGINEER HUNTER WATER CORPORATION		APPROVED MANAGER ASSET MANAGEMENT HUNTER WATER CORPORATION	

HUNTER WATER CORPORATION

A.C.N. 053 102 837



STANDARD DESIGN
RESERVOIR STANDARD

TYPICAL ENERGY DISSIPATOR ARRANGEMENT

FILE REFERENCE: HW2009-2368/3/6

HWCS

RES-112

ISSUED: MAY 2011

A3

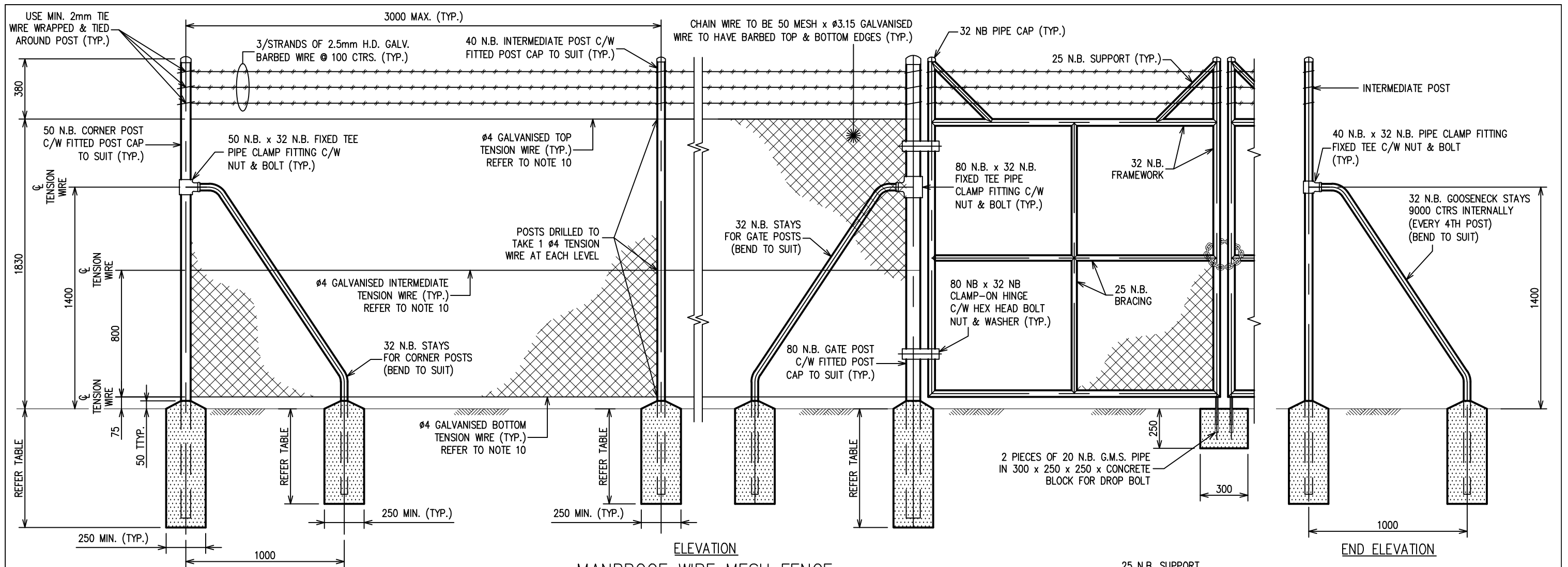

ELEVATION
MANPROOF WIRE MESH FENCE
SCALE 1:25

NOTES:

- GATES WIDER THAN 2000 TO HAVE 2 LEAVES EACH WITH 200 H.D. GALV. DROP BOLT. M10 H.D. GALV. CHAIN TO BE WELDED TO ONE LEAF FOR PADLOCK.
- ONLY APPROVED H.D. GALV. MILD STEEL FITTINGS & BOLTS TO BE USED. BOLTS TO BE BURRED AFTER NUTS ARE TIGHTENED.
- POSTS & STAYS TO BE H.D. GALV. MILD STEEL PIPES.
- ALL VERTICAL POSTS SHALL BE WEATHER CAPPED.
- POSTHOLES IN ROCK SHALL BE 50 LARGER THAN THE OUTSIDE OF THE PIPE. PIPE SHALL BE GROUTED IN WITH 3:1 SAND/CEMENT MORTAR
- POSTHOLES IN OTHER THAN ROCK TO BE MIN. 250 & BACKFILLED WITH GRADE N25 CONCRETE.
- ALL METALWORK TO BE HOT DIP GALVANISED AFTER FABRICATION TO AS4680.
- PERSONNEL ACCESS GATE - O/A DIMENSIONS NOM. 2080 x 900. INFILLED WITH CHAIN WIRE (SEE NOTE 9). SUPPLY 10mm GALVANISED PROOF COIL CHAIN (LENGTH TO SUIT).
- WHERE PROPRIETARY ITEMS ARE NOMINATED, TO BE TAKEN AS APPROVED EQUIVALENT.
- MESH TO BE TIED TO 4mm TENSION WIRE WITH 2mm TIE WIRE AS FOLLOWS:
-TOP STRAND > @ 400 CTRS.
-MIDDLE STRAND > @ 600 CTRS.
-BOTTOM STRAND > @ 500 CTRS.

	POST SIZE		DEPTH OF FOOTINGS	
	NOM. BORE	THICKNESS	IN O.T.R.	IN ROCK
CORNER POSTS	50	3.6	750	450
GATE POSTS	80	4.0	750	450
INTERMEDIATE POSTS	40	3.2	600	300
DIAGONAL STAYS	25	3.2	600	300
GOOSENECK STAYS	32	3.2	600	300

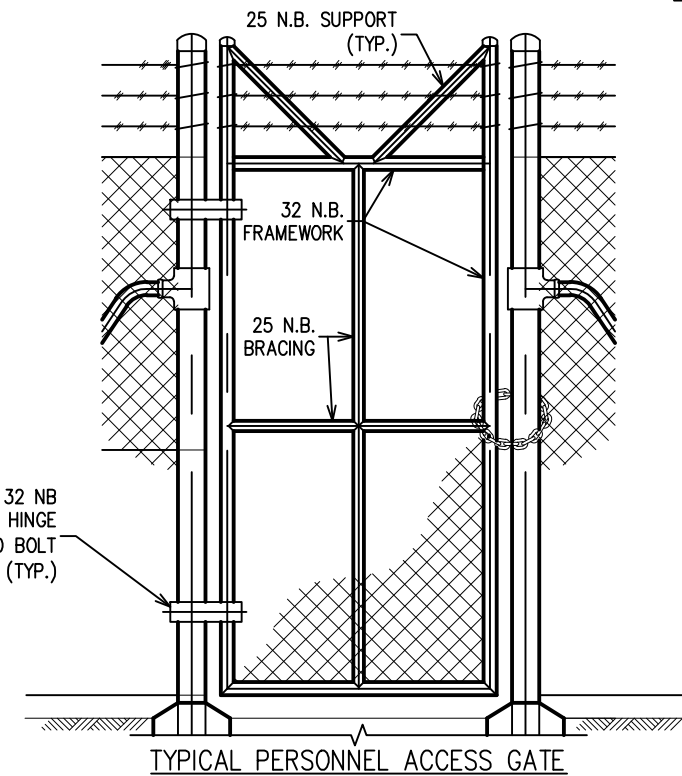

TYPICAL PERSONNEL ACCESS GATE

0	ISSUE	S.H	17.05.2011
REV No.	REVISION	APPROVED	DATE
© COPYRIGHT HUNTER WATER CORPORATION LIMITED. APPROVED ASSET STANDARD ENGINEER HUNTER WATER CORPORATION		APPROVED MANAGER ASSET MANAGEMENT HUNTER WATER CORPORATION	

HUNTER WATER CORPORATION

A.C.N. 053 102 837



STANDARD DESIGN
RESERVOIR STANDARD

TYPICAL SITE FENCING DETAILS

FILE REFERENCE: HW2009-2368/3/6

HWCS

RES-113

ISSUED: MAY 2011

A/3

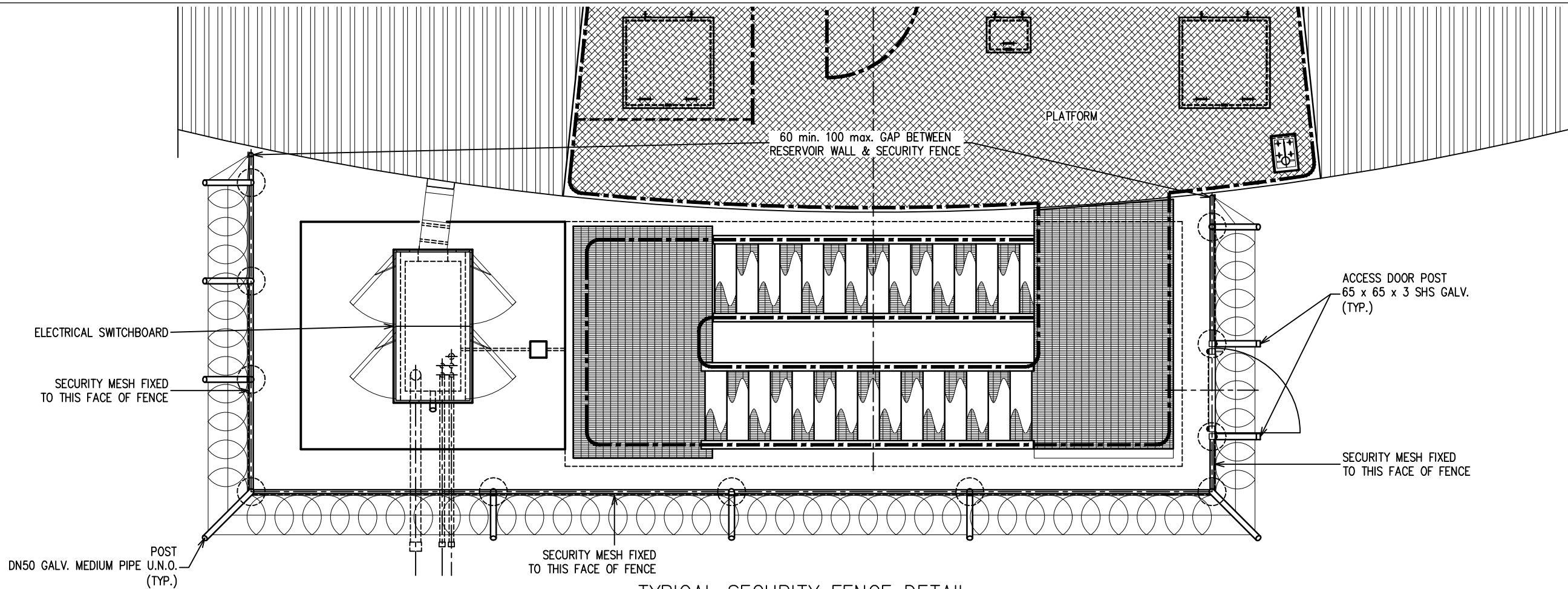

TYPICAL SECURITY FENCE DETAIL

SCALE 1:50

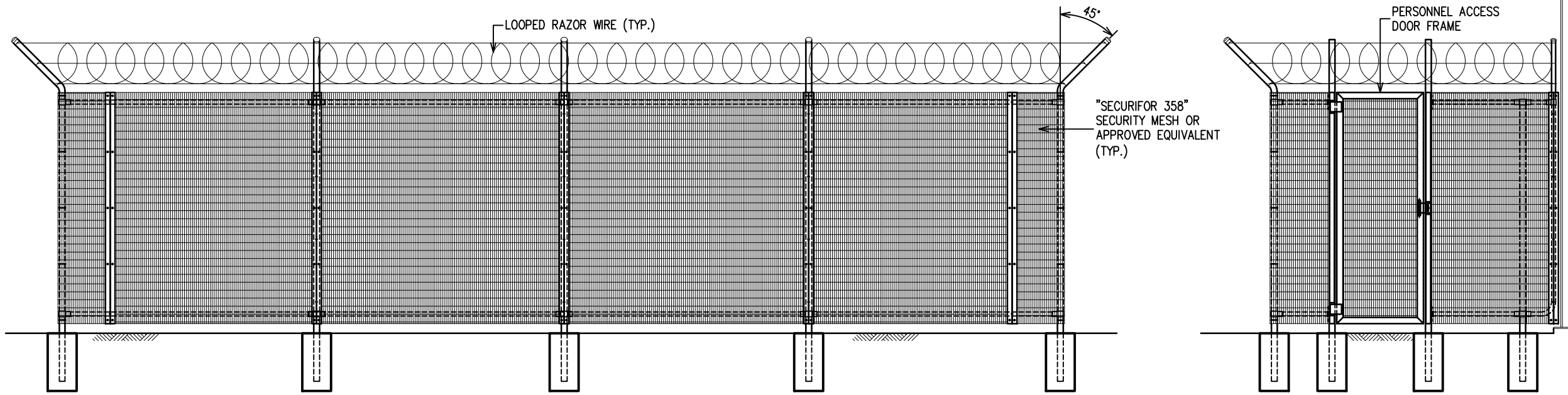

ELEVATION

SCALE 1:50

END ELEVATION

SCALE 1:50

NOTES

1. ALL COMPONENTS TO BE HOT-DIPPED GALV. FOLLOWING FABRICATION.
2. NO SITE WELDING OF COMPONENTS PERMITTED DURING INSTALLATION.
3. FIXINGS TO BE ANTI-TAMPER.

0	ISSUE		S.H	17.05.2011
REV No.	REVISION		APPROVED	DATE
© COPYRIGHT HUNTER WATER CORPORATION LIMITED.		APPROVED ASSET STANDARD ENGINEER HUNTER WATER CORPORATION		APPROVED MANAGER ASSET MANAGEMENT HUNTER WATER CORPORATION

HUNTER WATER CORPORATION

A.C.N. 053 102 837



STANDARD DESIGN
RESERVOIR STANDARD

TYPICAL SECURITY FENCE
ARRANGEMENT AND DETAILS

FILE REFERENCE: HW2009-2368/3/6

HWCS
RES-114

ISSUED: MAY 2011 | A.3

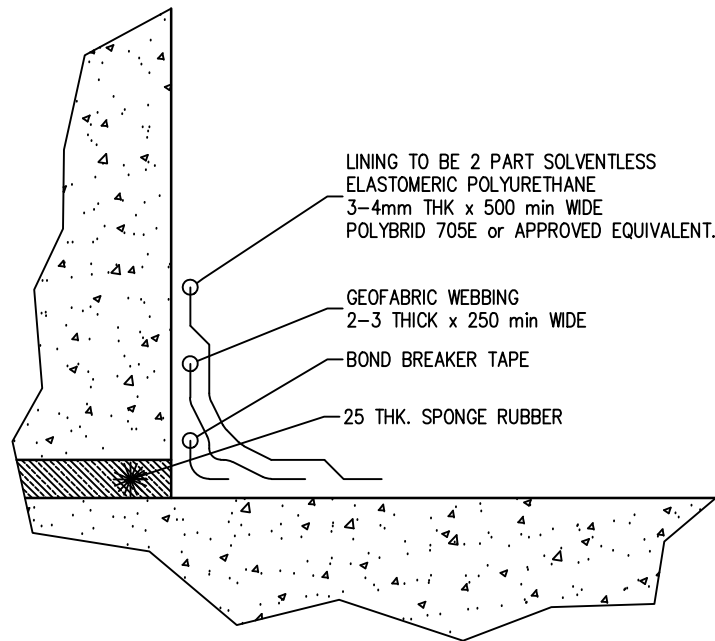

TYPICAL WATER SEAL
NOT TO SCALE

METHODOLOGY

1. PROFILE WATER BLAST WORK AREA (5000-6000 p.s.i.) AND ALLOW TO DRY
2. APPLY PRIMER
3. APPLY BOND BREAKER TAPE
4. INSTALL WEBBING / GEOFABRIC
5. APPLY POLYURETHANE LINING TO MANUFACTURERS WRITTEN INSTRUCTIONS.

0	ISSUE	S.H	17.05.2011
REV No.	REVISION	APPROVED	DATE
© COPYRIGHT HUNTER WATER CORPORATION LIMITED.		APPROVED ASSET STANDARD ENGINEER HUNTER WATER CORPORATION	
		APPROVED MANAGER ASSET MANAGEMENT HUNTER WATER CORPORATION	

HUNTER WATER CORPORATION

A.C.N. 053 102 837



STANDARD DESIGN
RESERVOIR STANDARD

TYPICAL CONCRETE WALL TO FLOOR DETAIL

FILE REFERENCE: HW2009-2368/3/6

HWCS

RES-115

ISSUED: MAY 2011

A3